

P345MTR and P345KPMTR

Multi-Technology

125 KHz and 13.56 MHz Readers



KANTECH™

Installation Manual

DN1870-1808

P345MTR and P345KPMTR Readers Installation Manual

Table of Contents

Introduction	5
Features	6
Mounting	6
Installation Considerations	8
Wiring	9
Installation Notes	10
Troubleshooting	11
Technical Specifications	12

Copyright Information

Copyright © 2018 Tyco International Ltd. and its Respective Companies. All rights reserved. All specifications were current as of publication date and are subject to change without notice. Kantech and the Kantech logo are trademarks of Tyco International Ltd. and its Respective Companies.

Technical Support

For technical assistance with the P345MTR, P345KPMTR and other Kantech products, contact technical support, Monday to Friday.

See the following table for the technical support phone numbers.

Country /Region	Phone Numbers	Support Hours	Email
North America (GMT - 05:00)			
US and Canada	Toll Free +1 888 222 1560 Direct: +450 444 2030	08:00 to 20:00	access-support@jci.com
Latin America (GMT - 03:00)			
Argentina, Buenos Aires	Direct: +54 11 5199 3104	08:00 to 20:00 access-support@jci.com	
Brazil, Sao Paolo	Direct: +55 11 3181 7377		
Chile, Santiago	Direct +56 2 3210 9662		

KANTECH™

Country /Region	Phone Numbers	Support Hours	Email
Colombia Bogota	Direct: +57 1 344 1422	08:00 to 20:00 access-support@jci.com	
Colombia, Cali	Direct: +57 2 891 2476		
Colombia, Medellin	Direct: +57 4 204 0519		
Costa Rica, National	Direct: +506 4 000 1655		
Dominican Republic, Santo Domingo	Direct: +1 829 235 3047		
El Salvador, San Salvador	Direct: +503 2 136 8703		
Guatemala, Guatemala City	Direct: +502 2 268 1206		
Mexico, Mexico City	Direct: +52 55 8526 1801		
Panama, Panama City	Direct: +507 836 6265		

P345MTR and P345KPMTR Readers Installation Manual

Country /Region	Phone Numbers	Support Hours	Email
Peru, Lima	Direct: +51 1 642 9707		
Venezuela Caracas	Direct: +58 212 720 2340		
Asia (GMT + 08:00)			
Asia	Toll free: +800 CALL TYCO Toll free: +800 2255 8926 Direct: +86 21 6023 0650		09:00 to 17:00 access-support@jci.com
China	Direct: +400 671 1528		
India	Direct: +1 800 1082 008		
Australia	Direct: +02 9684 3980		
EMEA (GMT + 01:00)			
EMEA	Toll free: +800 CALL TYCO Toll free: +800 2255 8926 Direct: +31 475 352 722		08:00 to 18:00 access-support@jci.com
United Kingdom	Direct: +44 330 777 1300		
Israel	Direct: +972 772 201 350		
Spain	Direct: +900 99 31 61		
France	Direct: +0800 90 79 72		

KANTECH™

Country /Region	Phone Numbers	Support Hours	Email
Germany	Direct: +0800 1806 757	08:00 to 18:00 access-support@jci.com	
Italy	Direct: +39 0230 510 112		
Belgium	Direct: +0800 76 452		
Ireland	Direct: +180 094 3570		
Bahrain	Direct: +800 04127		
Nordic countries	Direct: +45 4494 9001		
Denmark	Direct: +45 4494 9001		
Greece	Direct: +00800 3122 9453		
Russia	Direct: +81 0800 2052 1031		
Turkey	Direct: +00800 31923007		
United Arab Emirates	Direct: +800 03107123		
South Africa	Direct: +27 21100 3882		

FCC Digital Device Limitations

This device complies with Part 15 of the FCC rules Class A. Operation is subject to the following two conditions: (1) this device may not cause harmful interference, and (2) this device must accept any interference received including interference that may cause undesired operation. This Class A digital apparatus meets all requirements of the Canadian Interference Causing Equipment Regulations. The P345MTR and P345KPMTR readers are also compliant with EN55022:1998, amendment 1:1995, Class A.

In order to maintain compliance with FCC regulations, shielded cables must be used with this equipment. Operation with non-approved equipment or unshielded cables is likely to result in interference to radio and television reception.

CAUTION: Changes or modifications not expressly approved by Kantech for compliance could void the user's authority to operate this equipment.

UL Standards Compliance

The products are intended for use with UL 294 Listed access control units where compatibility with the reader(s) is indicated in the Listed control unit's installation instructions.

For these products, the HID KSF (Kantech Secure Format) and ioProx Kantech XSF have not been evaluated by UL.

UL has not evaluated the RS-485 Output of these readers.

The Tamper Circuit Electrical Rating for UL Installations (Pins 11 & 12) is 100 mA at 30 VDC.

The products comply with the following UL 294 performance levels:

Line Security: I

Destructive Attack: I

Endurance: IV

Standby Power: I

CE Compliance

- **EN50364:** Limitation of human exposure to electromagnetic fields from devices operating in the frequency range 0 Hz to 10 GHz, used in Electronic Article Surveillance (EAS), Radio Frequency Identification (RFID) and similar applications.
- **EN60950-1:** Information technology equipment. Safety. General requirements.
- **ETSI EN300 330-1:** Electromagnetic compatibility and Radio spectrum Matters (ERM); Short Range Devices (SRD); Radio equipment in the frequency range 9 kHz to 25 MHz and inductive loop systems in the frequency range 9 kHz to 30 MHz; Part 1: Technical characteristics and test methods.
- **ETSI EN300 330-2:** Electromagnetic Compatibility and Radio Spectrum Matters (ERM); Short Range Devices (SRD); Radio Equipment in the Frequency Range 9 kHz to 25 MHz and Inductive Loop Systems in the Frequency Range 9 kHz to 30 MHz; Part 2: Harmonized EN under Article 3.2 of the R&TTE Directive.
- **ETSI EN301 489-1:** Electromagnetic compatibility and Radio spectrum Matters (ERM); ElectroMagnetic Compatibility (EMC) standard for radio equipment and services; Part 1: Common technical requirements.
- **ETSI EN301 489-3:** Electromagnetic Compatibility and Radio Spectrum Matters (ERM); ElectroMagnetic Compatibility (EMC) Standard for Radio Equipment and Services; Part 3: Specific Conditions for Short-Range Devices (SRD) Operating on Frequencies between 9 KHz and 40 GHz.

RoHS (Restriction on Hazardous Substances)

This standard restricts the use of the following substances: Lead, cadmium, mercury, chromium IV, polybrominated biphenyl (PBB), and polybrominated diphenyl ether (PBDE) in electrical and electronic equipment by no later than July 1, 2006.

WEEE (Waste Electrical and Electronic Equipment)

This regulation is used for Waste Electrical and Electronic Equipment, and addresses the disposal and the environmental handling of these products.

Introduction

The **P345MTR** Contactless readers will read Prox and Smart Cards at frequencies of both 125 kHz and 13.56 MHz. The reading capability includes, for Smart Cards, both unencrypted serial numbers and encrypted MIFARE® programmed sectors. Refer to **Table 1** for a complete list of compatible standards and data.

The **P345KPMTR** reader has a built-in keypad with 12 keys, including CMD/ENTER and CE (Clear Entry). The reader outputs the PIN code in the 8-bit burst Wiegand. It also has the ability to read and verify the PIN on a Smart Card. This feature is enabled with the use of program cards. Please contact Kantech for more information on the PIN-on-Card function.

Table 1: Compatible Credential Formats

ioProx Kantech XSF	CASI-RUSCO® Prox Lite
HID KSF (Kantech Secure Format)	ISO 14443A (MIFARE®) Sector
HID® 26 Bit	ISO 14443B Serial Number
HID® Corporate 1000	ISO 15693 Serial Number
HID® 36 Bit Wiegand	MIFARE® Sector
HID® 37 Bit Wiegand	DESFire® Serial Number
Other HID pass through formats	iCLASS® Serial Number
Deister Prox SmartFrame®	Others - Future Expansion

Features

- Universal compatibility with most 125 kHz Prox (including all ioProx XSF and HID® Prox formats), all ISO 15693, and ISO 14443A credentials (badges, disk tags and key fobs). Reads both 125 kHz and 13.56 MHz credentials in the same reader.
- Electrical protection (reverse polarity diode protection on power lines).
- Data lines: high-speed transient voltage suppressor diodes.
- IP65-rated sealed electronics for deployment in both interior and exterior environments.
- Integrated reader tamper protection.

Mounting

Mount the single-gang backplate (with tamper magnet installed) onto the wall.

Figure 1: P345MTR Reader Backplate with Tamper Switch Magnet

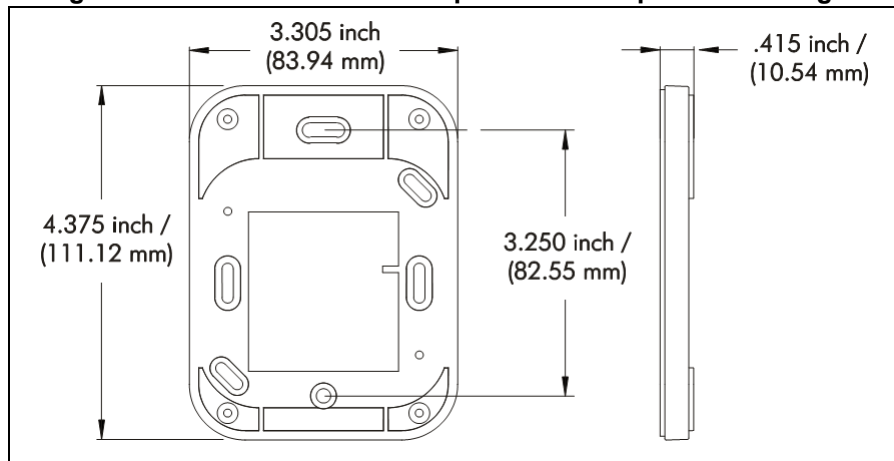

Note: Mounting holes fit standard U.S. single-width electrical box and standard European (EMEA) electrical box hole patterns.

Mount the reader module directly to the backplate and then snap the front cover in place as indicated in **Figure 2**.

Figure 2: Mounting Assembly with Isolation Spacer (Optional)

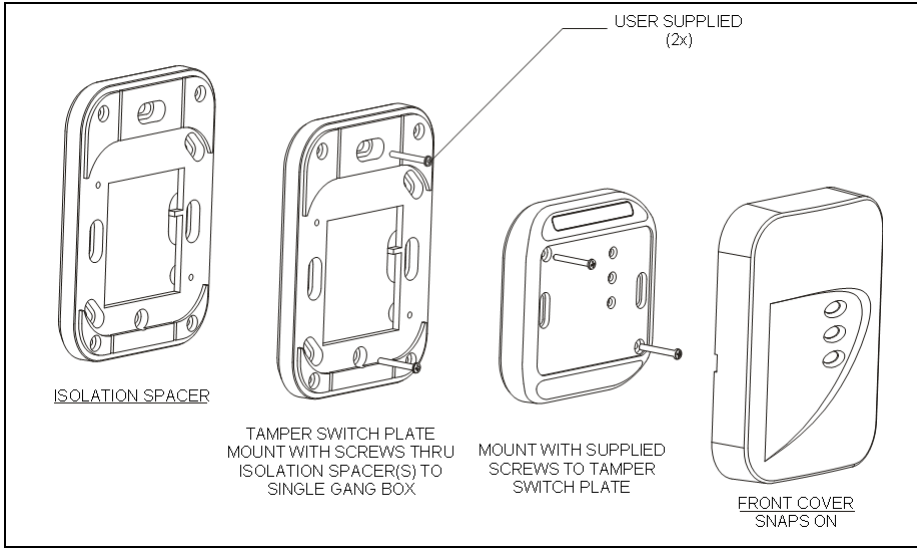

Please note that **Figure 2** shows the **P345MTR** reader and cover plate. Although the **P345KPMTR** keypad reader and front cover plate differ, the mounting assembly is the same as the **P345MTR**.

Installation Considerations

The **P345-SPACER** isolation spacer may be used to improve the read range distance when mounting the reader to a metal surface. To optimize reader range, use the number of backplates as indicated in **Table 2**. Use of Isolation Spacers is optional and not required for non-metal mounting surfaces.

Table 2: Isolation Spacer Recommendation for Mounting on Metal

Distance	Reading Distance
No metal plate	100%
4.5 cm	100%
2.7 cm (3 tamper plates)	85%
1.8 cm (2 tamper plates)	70%
0.9 cm (1 tamper plate)	50%
0 cm	10%

Installation of two P345MTR readers side-by-side and back-to-back

Read range is not affected if the center-to-center distance between two readers is greater than or equal to four (4) inches (101.6 mm). Two readers can simultaneously read the same badge or tag if the distance between the two readers is less than four inches, center-to-center. If the distance between the two readers is less than four inches, field interference between the two readers may result in a double-badge read.

Note: If two readers are being placed back-to-back on a wall less than four inches thick, maximum performance can be achieved by using a metal separation plate and then using isolation spacers as necessary.

Wiring

P345MTR models have twelve terminals as noted in **Table 3**. The terminal strip is removable for easy installation and wiring. When attaching wires to the connector, strip off only the minimum insulation required (approx. 1/8") and push the wire into the connector until the insulation is flush or inside the connector body. This is particularly critical for outdoor readers. While the reader itself is designed and protected to IP65 standards, the cable wires can potentially corrode and short together if not carefully mounted and tightly fastened in the connector body.

Table 3: Connector Pins

Pin	Description	Pin	Description
1	Buzzer	7	External Green LED Control
2	Ground	8	External Red LED Control
3	Power (9.4 to 16 VDC)	9	A - RS-485 - Used for Flash Upgrade
4	D1 Wiegand	10	B - RS-485 - Used for Flash Upgrade
5	D0 Wiegand	11	Tamper (Normally Closed)
6	Reserved for Future Use	12	Tamper (Normally Closed)

Table 4 indicates maximum wiring distances per Wiegand standard with the three most common gauges of cable.

Table 4: Maximum Cable Distance per Wire Gauge

Wire Gauge	18 AWG	20AWG	22 AWG
Cable Distance	500 feet (152 meters)	300 feet (91 meters)	200 feet (61 meters)

Installation Notes

Unless otherwise specified in this manual, please follow these guidelines:

Important: Use only shielded cabling for connections.

- 1 Connect the reader to the controller. See **Figure 3** for connecting the reader to a Kantech controller.

Note: You can use a local power supply for the reader. If so, don't connect the power supply from the controller to the reader. The ground line of the local power supply must be connected to the power supply of the controller.

Figure 3: Wiring Examples to Kantech Controllers

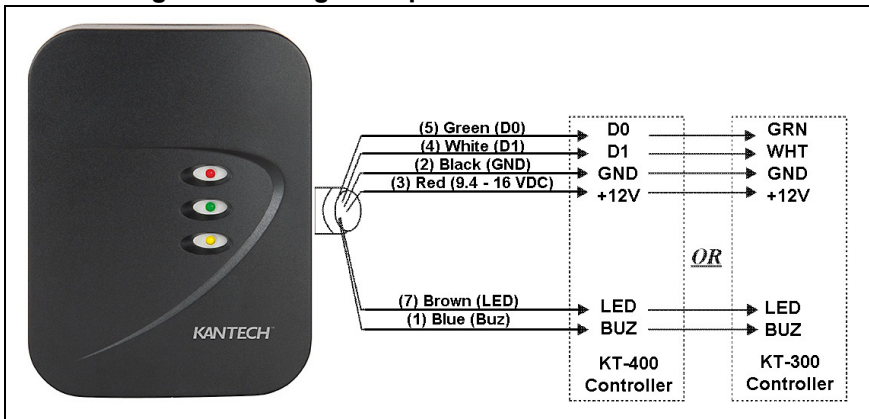

- 2 The unit needs to be operated with a power source with limited power consumption according to EN 60950-1 (2003) paragraph 2.5.
- 3 Use of a pull-up resistor may be required by some controllers others than Kantech controllers. Consult your controller manual.
- 4 For tamper wiring, connect Pins 11 and 12 to a normally closed supervised input.

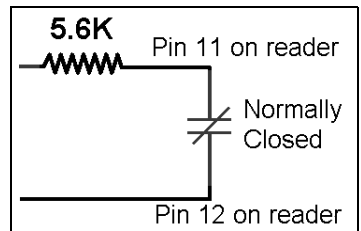

Troubleshooting

If the operation of a component is in doubt, substitute a known good component and retry the system. Always verify wiring against the provided wiring information before powering up the reader.

Table 5: Error Conditions and Possible Solutions

Condition	Possible Solutions
None of the LEDs are on.	Check the following: <ul style="list-style-type: none">■ Power connections to the reader.■ Reader supply voltage at connector pin 3 and that the ground connection pin 2 is secure and well connected.
The door does not open and the green LED does not light when a qualified credential is presented.	Verify that the door strike and the green LED are wired correctly. Verify that the access credential has been entered and that the reader has been properly configured in the host system.
The green LED does not light but the door strike unlocks the door when a valid credential is presented.	Verify that the door strike is wired correctly. Refer to the appropriate wiring diagram in your controller manual. Disconnect the wire from pin 7 (green LED) and connect pin 7 to pin 2 (ground). If the green LED is now on, the reader is good and the connection to the reader is defective. If the green LED does not light, replace the reader.

Technical Specifications

Cable Recommendations	4 core (minimum), shielded, 22 AWG (minimum) cable
Connectors	12 position, 3.5 mm Screw Terminals - Plug-In
Certifications	FCC Part 15, CE and UL 294
Open Standards Compliance	ISO 14443A ISO 14443B (Depending on specific implementation) ISO 15693 (including some partially compliant credentials)
Other Standards Compliance	Deister SmartFrame® in both 125 kHz and 13.56 MHz implementations HID Prox at 125 kHz (All Formats) HID KSF (Kantech Secure Format) ioProx Kantech XSF
PIN Code Entry Keys (Model P345KPMTR only)	Twelve PIN code entry keys 0-9, Command/Enter, and CE (Clear Entry)
Standard Color	Black
Dimensions with backplate (height / width / depth)	4.37 x 3.31 x 1.10 in (11.09 x 8.41 x 2.79 cm)
Power Supply	Rated Voltage: 9.4 to 16 VDC, 125 mA maximum current
Environments	For both Indoor and Outdoor Use
Humidity	5 to 90% (non-condensing)
Operating Temperature	-31°F to 151°F (-35°C to 67°C)
Index of Protection	IP 65 (IEC 529)

KANTECH™

Read Range	1 to 5 in. (2.5 to 12.7 cm) depending on credential technology and environment. Note: Read range for credentials of identical technologies may vary greatly depending on the tuning and antenna structure of each individual credential.
Standard Wiegand Output including	ID Pass-Through Option Serial Number Read Fixed Wiegand bit stream option SmartFrame® encrypted MIFARE Sector read and conversion to Wiegand. Consult your Kantech representative for available reconfiguration cards for your reader. 8-bit burst Wiegand PIN code (P345KPMTR only) PIN-on-card featured (P345KPMTR only)
Upgrade (Future Use)	Complete upgrade capability using RS-485 port for reflashing of internal ROM.

KANTECH[™]

Copyright © 2018 Tyco International Ltd. and its Respective Companies.
All rights reserved.
www.kantech.com



D29010395R001