

# **PC5950**

## Universal VOX Audio Verification Module Installation Manual

---

*WARNING: This document contains information on limitations regarding product use and function and information on the limitations as to liability of the manufacturer. The entire manual should be carefully read.*

---

## FCC COMPLIANCE STATEMENT

**CAUTION:** Changes or modifications not expressly approved by Digital Security Controls could void your authority to use this equipment. This equipment has been tested and found to comply with the limits for a Class B digital device, pursuant to Part 15 of the FCC Rules. These limits are designed to provide reasonable protection against harmful interference in a residential installation. This equipment generates, uses and can radiate radio frequency energy and, if not installed and used in accordance with the instructions, may cause harmful interference to radio communications. However, there is no guarantee that interference will not occur in a particular installation. If this equipment does cause harmful interference to radio or television reception, which can be determined by turning the equipment off and on, the user is encouraged to try to correct the interference by one or more of the following measures:

Re-orient the receiving antenna.

Increase the separation between the equipment and receiver.

Connect the equipment into an outlet on a circuit different from that to which the receiver is connected.

Consult dealer or experienced radio/television technician for help.

The user may find the following booklet prepared by the FCC useful: 'How to Identify and Resolve Radio/Television Interference Problems'. This booklet is available from the U.S. Government Printing Office, Washington D.C. 20402, Stock # 004-000-00345-4.

### IMPORTANT INFORMATION

This equipment complies with Part 68 of the FCC Rules and the requirements adopted by the ACTA. On the side of this equipment is a label that contains, among other information, a product identifier in the format US:AAAEQ##TXXXX. If requested, this number must be provided to the Telephone Company.

Product identifier: US:F53KX01BPC5950

USOC Jack: RJ-31X

### Telephone Connection Requirements

A plug and jack used to connect this equipment to the premises wiring and telephone network must comply with the applicable FCC Part 68 rules and requirements adopted by the ACTA. A compliant telephone cord and modular plug is provided with this product. It is designed to be connected to a compatible modular jack that is also compliant. See installation instructions for details.

### Ringer Equivalence Number (REN)

The REN is used to determine the number of devices that may be connected to a telephone line. Excessive RENs on a telephone line may result in the devices not ringing in response to an incoming call. In most but not all areas, the sum of RENs should not exceed five (5.0). To be certain of the number of devices that may be connected to a line, as determined by the total RENs, contact the local Telephone Company. For products approved after July 23, 2001, the REN for this product is part of the product identifier that has the format US: AAAEQ##TXXXX. The digits represented by ## are the REN without a decimal point (e.g., 03 is a REN of 0.3). For earlier products, the REN is separately shown on the label.

### IC: 160A -PC5950

**NOTICE:** This equipment meets the applicable Industry Canada Terminal Equipment Technical Specifications. This is confirmed by the registration number. The abbreviation, IC, before the registration number signifies that registration was performed based on a Declaration of Conformity indicating that Industry Canada technical specifications were met. It does not imply that Industry Canada approved the equipment.

**NOTICE:** The Ringer Equivalence Number (REN) for this terminal equipment is 0.1. The REN assigned to each terminal equipment provides an indication of the maximum number of terminals allowed to be connected to a telephone interface. The termination on an interface may consist of any combination of devices subject only to the requirement that the sum of the Ringer Equivalence Numbers of all the devices does not exceed 5.

### Incidence of Harm

If this equipment PC5950 causes harm to the telephone network, the telephone company will notify you in advance that temporary discontinuance of service may be required. But if advance notice is not practical, the Telephone Company will notify the customer as soon as possible. Also, you will be advised of your right to file a complaint with the FCC if you believe it is necessary.

### Changes in Telephone Company Equipment or Facilities

The Telephone Company may make changes in its facilities, equipment, operations or procedures that could affect the operation of the equipment. If this happens the Telephone Company will provide advance notice in order for you to make necessary modifications to maintain uninterrupted service.

### Equipment Maintenance Facility

If trouble is experienced with this equipment PC5950, contact the facility indicated below for repair or warranty information. If the equipment is causing harm to the telephone network, the Telephone Company may request that you disconnect the equipment until the problem is solved. This equipment is of a type that is not intended to be repaired by the end user.

DSC c/o APL Logistics, 757 Douglas Hill Rd., Lithia Springs, GA30122, USA

### Additional Information

Connection to party line service is subject to state tariffs. Contact the state public utility commission, public service commission or corporation commission for information.

Alarm dialing equipment must be able to seize the telephone line and place a call in an emergency situation. It must be able to do this even if other equipment (telephone, answering system, computer modem, etc.) already has the telephone line in use. To do so, alarm dialing equipment must be connected to a properly installed RJ-31X jack that is electrically in series with and ahead of all other equipment attached to the same telephone line. Proper installation is depicted in the figure below. If you have any questions concerning these instructions, you should consult your telephone company or a qualified installer about installing the RJ-31X jack and alarm dialing equipment for you.

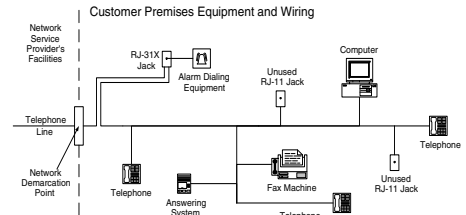

**AVIS:** Le présent matériel est conforme aux spécifications techniques d'Industrie Canada applicables au matériel terminal. Cette conformité est confirmée par le numéro d'enregistrement. Le sigle IC, placé devant le numéro d'enregistrement, signifie que l'enregistrement s'est effectué conformément à une déclaration de conformité et indique que les spécifications techniques d'Industrie Canada ont été respectées. Il n'implique pas qu'Industrie Canada a approuvé le matériel.

**AVIS:** L'indice d'équivalence de la sonnerie (IES) du présent matériel est de 0.1. L'IES assigné à chaque dispositif terminal indique le nombre maximal de terminaux qui peuvent être raccordés à une interface téléphonique. La terminaison d'une interface peut consister en une combinaison quelconque de dispositifs, à la seule condition que la somme d'indices d'équivalence de la sonnerie de tous les dispositifs n'exécède pas 5.

# Table of Contents

| Section |  | Page      |
|---------|--|-----------|
| 1       | <b>Introduction .....</b>                  | <b>1</b>  |
| 1.1     | Specifications.....                        | 1         |
| 1.2     | Out-of-the-Box .....                       | 2         |
| 2       | <b>Installation .....</b>                  | <b>3</b>  |
| 2.1     | PC5950 Installation.....                   | 3         |
| 2.2     | Audio Station Wiring .....                 | 3         |
| 3       | <b>Operation .....</b>                     | <b>7</b>  |
| 3.1     | Configurations.....                        | 7         |
| 3.2     | KEYBUS Configuration.....                  | 7         |
| 3.3     | Universal Configuration .....              | 7         |
| 3.3.1   | Auto-sense Mode .....                      | 7         |
| 3.3.2   | Triggered Mode .....                       | 7         |
| 3.4     | Audio Control Telephone Key Functions..... | 7         |
| 3.5     | Operating Tones .....                      | 7         |
| 4       | <b>Programming .....</b>                   | <b>10</b> |
| 4.1     | Programming - Keybus Mode.....             | 10        |
| 4.2     | Programming - Universal Mode.....          | 16        |
| 4.3     | Programming - User.....                    | 18        |

# 1. Introduction

The PC5950 series Universal VOX Audio Verification Modules provide 'Talk/Listen-in' capability for the audio verification of alarms. The PC5950 permits the central station to monitor microphones and communicate to occupants through speakers. The central station can control volume etc. with telephone key presses in accordance with SIA Audio Verification protocol. The user can also remotely initiate audio monitoring of the premises.

The PC5950 series modules connects directly to PowerSeries control panels via the KEYBUS. Third-party alarm panels can be connected using the Bell output and a programmable output (PGM). A Telco connection is provided for telephone line connections (required for Audio Verification). The PC5950 Talk/Listen-in options are accessible by the central station operator using telephone keys (1-9) and (\*). See 'Audio Control Telephone Key Functions' on page 8.

The module mounts in the main control panel cabinet (PC5003C) using existing mounting holes (see figure 2: Installation). In Keybus Mode, all programming can be performed at the system keypad or remotely using DLS software (DSC Panels only). In Universal mode the unit is programmed via key presses from a remote telephone.

**Figure 1: PC5950 Audio Verification Module**

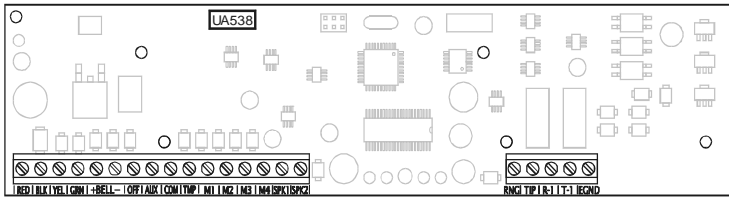

## 1.1 Specifications

|                                      |  |
|--------------------------------------|--|
| Operating Temperature Range:         | 32°-122°F (0°-50°C)                                      |
| Humidity:                            | 0-to-93% non-condensing                                  |
| Operating Voltage (RED, BLK)         | 11.0 - 13.8 VDC (max)                                    |
| Current Draw (Board Only)            | 54mA (max)   |
| Current Draw (Max)                   | 150mA (max)  |
| AUX Output:                          | 11.5 - 12.5 VDC  |
| PC5904                               | 175 mA (max)   |
| PC5921                               | 50 mA (max)  |
| PC5961, PC5962                       | 60 mA (max)  |
| PC5964                               | 200 mA (max)   |
| Wiring Distance (All Audio Stations) | 500ft (152m)   |
| Audio Range:                         |  |
| PC5961, PC5962                       | 25ft.(7.6m)  |
| PC5964                               | 50ft. (15.2m)  |
| Compatible Control Panels            | PC5010, PC5020, PC1864, PC1832, PC1808, PC1616, PC1555MX |
| Associated Modules:                  |  |
| PC5921                               | Audio Station with Page and DND buttons                  |
| PC5904                               | 2-way Audio station                                      |
| PC5961                               | 2-way Audio Station                                      |
| PC5962                               | Contoured 2-way Audio Station                            |
| PC5964                               | 2-way Audio Station                                      |

## 1.2 Out of the Box

The PC5950 Kit includes the following:

- 1 PC5950 Audio Verification Module
- 4 Stand-offs
- 1 Installation Manual
- 1 User Guide

**Figure 2: Installation**

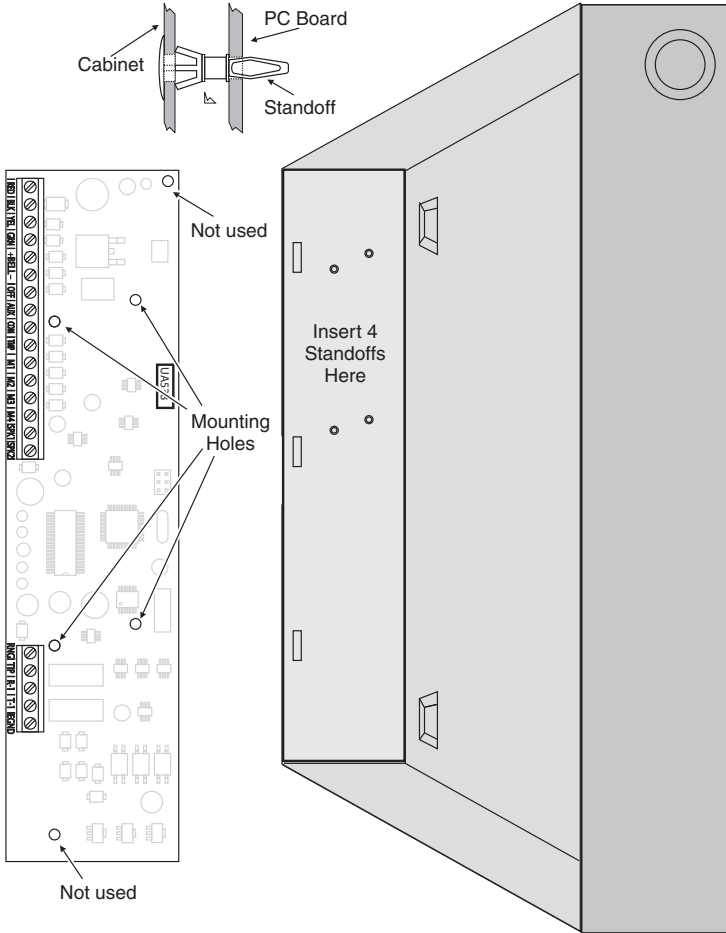

### **CAUTION!**

Do not route wiring over the PC5950 module. Maintain at least 1" (25.4mm) separation. A minimum distance of 1/4" (6.44mm) must be maintained at all points between power limited and non-power limited wiring.

---

## 2. Installation

### 2.1 PC5950 Installation

The PC5950 module must be installed by Service Personnel only. It must be installed in a metallic cabinet properly grounded. It is the installer's responsibility to ensure a degree of protection for the equipment such that no access to the TNV circuit is given to the end user. The metallic cabinet must be secured to the building structure before operation. A proper ground connection must be provided for the metal cabinet. Internal wiring must be routed in a manner that prevents:

- excessive strain on wire and on terminal connections
- loosening of terminal connections
- damage to conductor insulation

Follow these steps to install the PC5950 audio interface module and audio stations. Review this section to get an overall understanding of the order of installation. Once this is done, carefully work through each step.

1. Insert the 4 stand-offs provided in the position indicated in figure 3. The stand-offs will make an audible 'click' when positioned correctly.
2. Position the module over stand-offs, press firmly to ensure that the module locks in place.
3. Wire the module to the Control Panel, microphones, speakers or Escort as required (figure 3).

**NOTE:** Do **NOT** use shielded wire on KEYBUS wire runs. The distributed capacitance of shielded wire can significantly reduce signal quality and range. Wire all other connections with 22AWG shielded wire

4. Program module as required (see section 3 Programming).
5. Verify operation.

### 2.2 Audio Station Wiring

Up to 4 audio stations (4 microphones and 2 speakers) can be connected to the PC5950 audio interface module. Each Audio Station must be home-run to the interface module via 22 gauge, 4-conductor cable. Each Audio Station can be up to 500ft (152m) from the PC5950. Connect each station to the audio connections on the PC5950 module as indicated in figure 3.

**Figure 3: PowerSeries/Universal Wiring Diagrams**

**A PowerSeries Wiring Diagram**

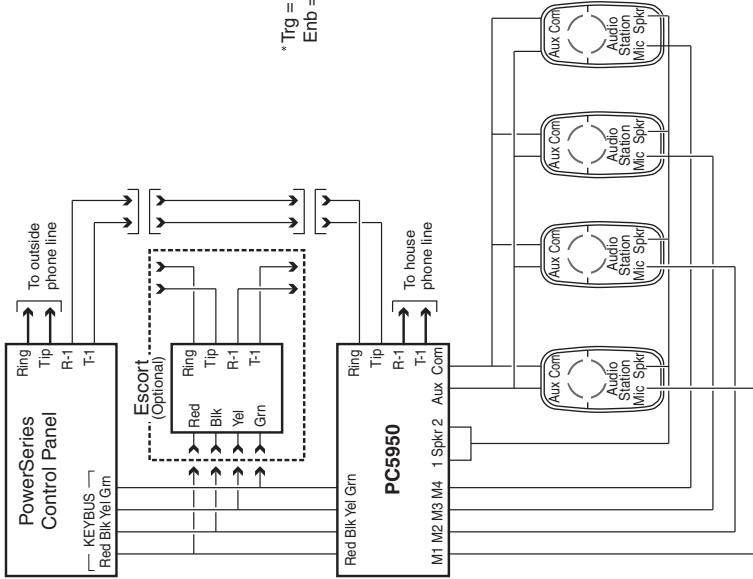

**Note:** Any combination of Audio Stations can be used as long as the maximum current draw is not exceeded:  
 4 Small Stations (PC5561/PC5962)  
 2 Large Stations (PC5564)  
 1 Large & 2 Small Stations

**B Universal Configuration Wiring Diagram**

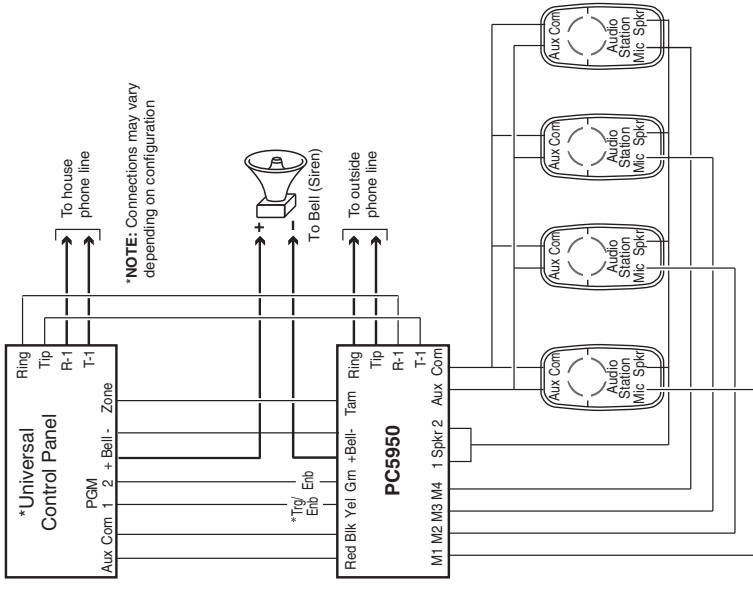

\* Trg = Trigger  
 Enb = Enable

\*NOTE: Connections may vary depending on configuration

**NOTE:** Speaker outputs SPK1, SPK2 are connected internally. Do NOT exceed 2 speakers per terminal

**NOTE:** The diagram above applies to negative triggered Bell. If the panel has a positive triggered Bell then a relay is required.

Figure 4: PC5950 - Vista 20 Wiring Diagram

**Wiring Diagram for the PC5950 with the Vista 20 Panel**

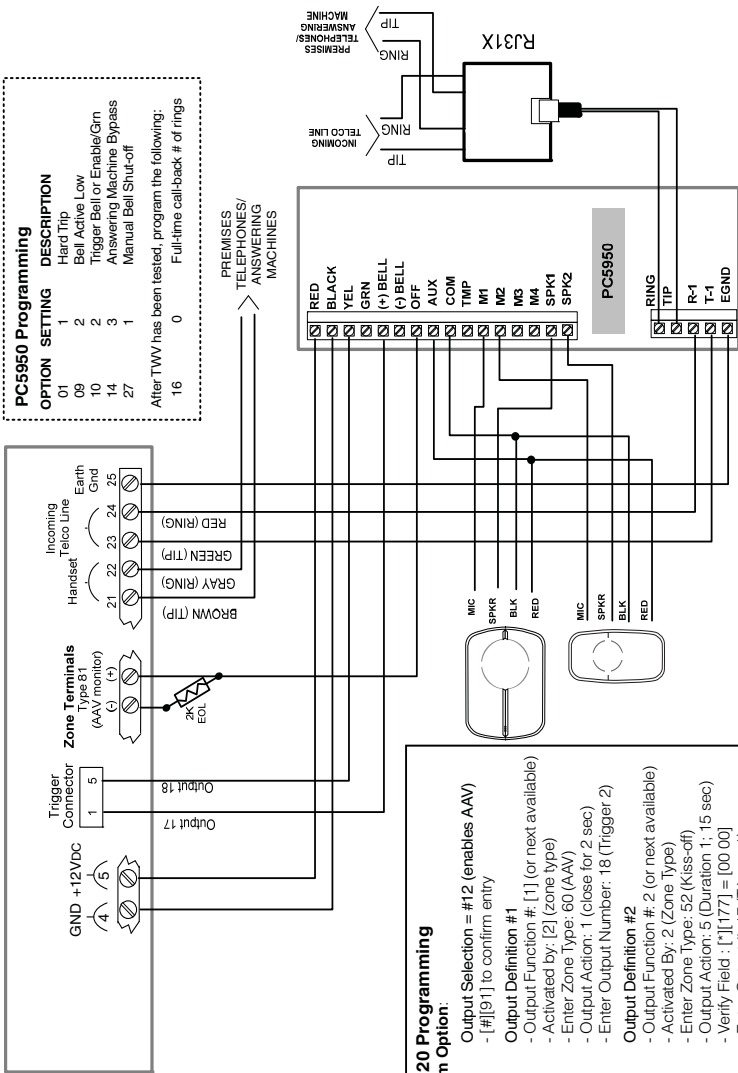

**Vista 20 Programming**

**System Option:**

- [\*][9][1] Output Selection = #12 (enables AAV)
  - [#][9][1] to confirm entry
- [\*][8][0] Output Definition #1
  - Output Function #: [1] (or next available)
  - Activated by: [2] (zone type)
  - Enter Zone Type: 60 (AAV)
  - Output Action: 1 (close for 2 sec)
  - Enter Output Number: 18 (Trigger 2)
- Output Definition #2
  - Output Function #: 2 (or next available)
  - Activated By: 2 (Zone Type)
  - Enter Zone Type: 52 (Kiss-off)
  - Output Action: 5 (Duration 1; 15 sec)
  - Verify Field: [\*][1][7] = [00 00]
  - Enter Output #: 17 (Trigger 1)

[\*][5][6] Enter Zone Programming

Select a zone number, used for the voice session monitoring zone (ex. [0][8][\*]).

- Select AAV feedback zone type ([8][\*][\*])
- Press [\*] to pass partition (RC, HW type etc.)



**Figure 5: PC5950 Terminal Connections**

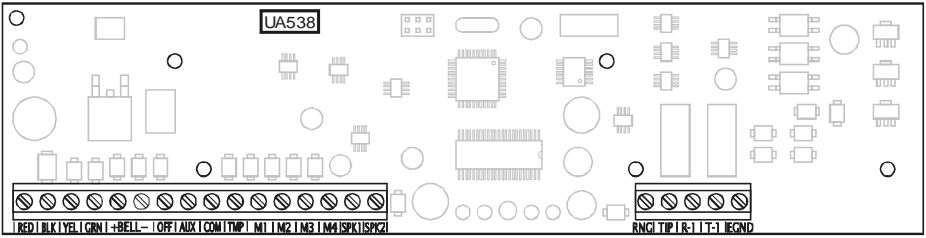

|             |                             |   |
|-------------|-----------------------------|---|
| Keybus      | RED<br>BLK<br>YEL<br>GRN    | KEYBUS Power ( <i>Aux+ from Universal Panel</i> )<br>KEYBUS Ground ( <i>Com from Universal Panel</i> )<br>KEYBUS Clock Input ( <b>Trigger Mode:</b> TRG- <i>Kissoff</i> , <b>Auto-sense Mode:</b> <i>Enable input from 3rd party PGM</i> )<br>KEYBUS Data Input / Output ( <i>Enable input from 3rd party PGM</i> )   |
| Bell        | Bell +<br><br>Bell -<br>OFF | Bell (Bell input from Universal Panel Bell)<br><b>NOTE:</b> If the Bell Output from the alarm panel is negative it can be connected directly to the PC5950 Bell+ Terminal. Positive triggered outputs require a relay to shunt the Bell+ terminal to the COM terminal.<br>Bell (Bell Output)<br>For Future Use  |
| Aux Power   | AUX<br><br>COM              | Auxiliary Power Output AUX (PTC protected locally).<br><b>NOTE:</b> Output current is limited by the available current at panel the AUX/ RED output (refer to the control panel <i>Installation Manual</i> )<br>Common Ground   |
| Tamper      | TMP                         | Speaker Tamper ( <i>Triggered by zone activation from Universal Panel</i> )   |
| Speaker/Mic | M1<br>M2<br>M3<br>M4        | Microphone #1 Input Channel<br>Microphone #2 Input Channel<br>Microphone #3 Input Channel<br>Microphone #4 Input Channel  |
| Speakers    | SPK1<br>SPK2                | Speaker Level Output (supports two DSC Audio Stations)<br>Speaker Level Output (supports two DSC Audio Stations)<br><b>NOTE:</b> SPK1 and SPK2 are parallel wired from a single audio output. Any combination of Audio Stations can be used as long as maximum the current draw is not exceeded:<br><ul style="list-style-type: none"> <li>- 4 Small Stations (PC5961/62)</li> <li>- 2 Large Stations (PC5964)</li> <li>- 1 Large &amp; 2 small Stations</li> </ul> |
| Phone Line  | RNG<br>TIP<br>R-1<br>T-1    | TELCO Ring connection from panel<br>TELCO Tip connection from panel<br>TELCO Ring connection to in-house phones<br>TELCO Tip connection to in-house phone   |
| Ground      | EGND                        | Earth Ground  |

---

## 3. Operation

### 3.1 Configurations

The PC5950 operates in two different configurations, Keybus and Universal. The Keybus configuration is intended for use with DSC Alarm Panels that have a Keybus. This configuration provides additional features (see figure 3A). The Universal Configuration is intended for use with third-party alarm systems (see figure 3B). PC5950 searches for a Keybus on startup. If a Keybus is not found within 20 seconds, the system automatically configures itself in the Universal configuration.

### 3.2 Keybus Configuration

This wiring configuration applies to DSC panels only. The PC5950 connects directly to the PowerSeries panel Keybus in this wiring configuration. The module can be directly programmed from the system keypad by entering [\*][8][Installer Code][802] followed by the associated section numbers found in section 4 of this manual.

### 3.3 Universal Configuration

This wiring configuration applies to alarm systems that do not support Audio Verification or do not have a Keybus. The Universal configuration can operate in the Auto-sense Mode or in Trigger Mode

#### 3.3.1 Auto-sense Mode

In this mode the PC5950 is activated by an output from the alarm panel that indicates that an event has been transmitted that requires a 2-way audio session (e.g., System Event). The module senses when the panel has finished communicating and then seizes the line and initiates a 2-way audio session based on the criteria listed in the table below.

**NOTE: If a silent alarm is used to initiate a 2-way audio session, the PGM output should be programmed to follow a timer. This will ensure that subsequent silent alarms will initiate a 2-way audio session.**

#### 3.3.2 Trigger Mode

In this mode the PC5950 is activated by an output from the alarm panel that indicates that an event has been transmitted that requires a 2-way audio session to be initiated immediately (e.g., Kissoff). The module immediately seizes the line and initiates a 2-way audio session based on the criteria listed in the table below.

**Trigger input (Yel terminal):** This is a required connection which is connected to a kiss-off output on the panel and is required to initiate 2-way audio.

**Bell input:** This is optional based on toggle option [10] in universal programming. This is connected to bell of the control panel (please see diagram B for wiring connections).

**Grn input:** This is optional based on toggle option [10]. This is connected to a PGM output on the panel to trigger 2-way only on special events.

**Table 2.1, Auto-sense Mode & Trigger Mode Criteria**

| Enable Required Option | Trig/PGM | Enable/Bell | Auto/Sense Mode | Triggered Mode |
|------------------------|----------|-------------|-----------------|----------------|
| 1                      | Inactive | Inactive    | None            | None           |
| 1                      | Active   | Inactive    | None            | None           |
| 1                      | Inactive | Active      | Talk/Listen     | None           |
| 1                      | Active   | Active      | Talk/Listen     | Talk/Listen    |
| 2                      | Inactive | Inactive    | None            | None           |
| 2                      | Active   | Inactive    | Listen          | Listen         |
| 2                      | Inactive | Active      | Talk/Listen     | Talk/Listen    |
| 2                      | Active   | Active      | Talk/Listen     | Talk/Listen    |

### 3.4 Audio Control Telephone Key Functions

The PC5950 functions are controlled using the [\*] key during a telephone session as per the SIA Audio Verification Standard. Enter [\*] followed by [0] or [1] to select a level, followed by the 1- or 2-digit key number of the desired action. Alarm and Talk/Listen options can occur from any partition on the system.

**NOTE:** When an audio verification session has been initiated, the module is in 'line hold' mode and waits for the operator to press a touch-tone digit (only when Manual Bell Shut-off Option [27] is selected).

**NOTE:** Use Disconnect key [99] or [88] to terminate a session before hanging up.

Entering [\*][0] followed by [0] - [99] selects the following options:

|      |  |
|------|--|
| [0]  | <b>Future Use</b>  |
| [1]  | <b>High Gain Talk-to-all</b><br>Connects the Central Monitoring Station to all Speakers at Hi volume level   |
| [2]  | <b>Two-way VOX</b><br>Connects the Central Monitoring Station to all Speakers and all active microphones. An internal voice switch automatically switches between "Listen" and "Talk" modes  |
| [3]  | <b>Hi-gain Listen to all active Microphones</b><br>Connects the Central Monitoring Station to all active microphones at Hi gain level  |
| [4]  | <b>Lo-gain Talk-to-all</b><br>Connects the Central Monitoring Station to all Speakers at Lo volume level   |
| [5]  | <b>Future Use</b>  |
| [6]  | Lo-gain Listen to all active Microphones<br>Connects the Central Monitoring Station to all active microphones at Lo gain level   |
| [7]  | <b>Extend Time</b><br>Restarts the session timer to prevent time-out.  |
| [88] | <b>Disconnect with Call-back Window</b><br>Disconnects the session then starts the Call-back Window (if programmed) to allow the Central Monitoring Station to resume the session later.<br><b>NOTE:</b> The second '8' must be pressed within 1 second of pressing the first '8'. |
| [99] | <b>Disconnect</b><br>Terminates the session.<br><b>NOTE:</b> The second '9' must be pressed within 1 second of pressing the first '9'.   |

Entering [\*][1] followed by [0] - [9] selects the following options:

|         |   |
|---------|---|
| [0]-[1] | <b>Future Use</b>   |
| [2]     | <b>Microphone Select</b><br>Enter 0 - 5 to toggle (enable or disable depending on the previous state) the associated microphone. This allows the Central Station Operator to deselect undesirable microphone inputs. Selecting 0 turns all inputs OFF. Selecting 5 turns all inputs ON. Selecting 1 - 4 toggles the corresponding microphone. |
| [3]     | <b>Zone Select 01 - 64 (Keybus mode only)</b><br>Enter a 2-digit zone number (01-64) after entering this key to activate a microphone input associated with the zone for a listen-in session. If the selected zone does NOT have microphone input, the function is cancelled and the module reverts to the previous state.                    |
| [4]     | <b>Increment Selected Microphone</b><br>Selects the next enabled microphone in the sequence.  |
| [5]     | <b>Decrement Selected Microphone</b><br>Selects the previous enabled microphone in the sequence.  |
| [6]-[9] | <b>Future Use</b>   |

### 3.5 Operator Tones

The tones generated by the PC5950, while in 2-way, are as follows:

|                                |   |
|--------------------------------|---|
| <b>Start Tone</b>              | High, High, High, 100ms long/100ms apart    |
| <b>End Tone</b>                | High, High, High, 100ms long/100ms apart    |
| <b>Subsequent Alarm Tone</b>   | High, Low, High, Low 100ms long/100ms apart |
| <b>20-second Time-out Tone</b> | High Tone for 100ms                         |
| <b>10-second Time-out Tone</b> | Low Tone for 100ms                          |

---

## 4. Programming

### 4.1 Programming - Keybus Mode

If programming the PC5950 via DLS (Keybus configuration), select PC5950 for the correct programming options.

Enter **[\*][8][Installer Code][802]** on the system keypad followed by the desired subsection (listed below) to program options.

**NOTE:** The PC5950 can only be programmed using DLS when it is connected to a PowerSeries panel.

**NOTE:** Numbering of this section corresponds with the numbering of the *Programming Worksheets*.

#### [04] Call Back/Recovery Window Duration

The duration of time that the central station receiver is able to call back the panel in the event of a dropped phone line. See section [10], Option [5] below. Valid Entries are 01-09 minutes, 00 to disable.

#### [05] Call Back Acknowledge Code

This code must be entered by the Central Monitoring Station Operator when calling during the call back recovery window. If a valid code is entered, 2-way audio is initiated and if an invalid code is entered then an error tone is generated. Valid Entries are 000000-999999.

#### [06] Answering Machine Bypass

If a home answering machine is enabled, the user can call using the Double-Call option to connect to the module and initiate a 2-way audio session. After hearing the number of rings programmed, hang up the line and redial after a minimum of 6 seconds, the module will be connected on the second call. Number of Rings (Valid Entries 01-09, 00 to disable).

**NOTE:** Program this section with a value greater than 2 for DLS Double-call support.

#### [07] Answering Machine Bypass Double-call Timer

This is the duration between 2 calls when using the Answering Machine Bypass. The second call should be made within the programmed time or answering machine bypass is cancelled. Number of Rings (Valid Entries 00-99 seconds).

#### [08] Number of Rings to Answer On

Number of Rings (Valid Entries 01-09, 00 to disable).

#### [10] Audio Options

**Option [2]** when enabled the Alarm and Talk / Listen option occurs for events from all zones and partitions. If Option [2] is not selected the Talk/Listen option will only be initiated for zones in alarm.

**Option [3]** when enabled the audio stations will sound on an audible alarm event.

**Option [4]** when enabled the tamper output is high and low when disabled.

**Option [5]** when enabled the PC5950 can detect if the central station receiver has dropped the phone line. It will then hang up the line and enable a 5-minute call-back window (the default is 005; this can be changed in section [04]).

**Option [6]** when enabled it allows the user to call from a remote phone and initiate a 2-way voice session.

**Option [8]** when enabled a DTMF digit is required to enter 2-way audio and turn off the bell.

#### [14] Audio Station Tamper Options

Enables or disables audio tampers for 4 speakers/microphones. Default is disabled.

#### [30]-[37] Audio Control Options

These sections enable/disable specific Zone Alarms that will initiate an audio verification session.

#### [38] Ninth Audio Control Options (Listen-In Options)

These options enable/disable system events that cause the panel to initiate **Talk/Listen-In** upon completion of the communication handshake. The following system events can be programmed to initiate Talk/Listen-In.

|                  |   |                      |   |
|------------------|---|----------------------|---|
| Tampers          | N | Duress Alarm         | N |
| Openings/Closing | N | Zone Exp. Sup. Alarm | N |
| [A] Alarm        | N | Open After Alarm     | N |
| [P] Alarm        | N |                      |   |

**NOTE:** The Alarm and Talk/Listen-in options will occur for events from any partition (entire system).

## [40]-[47] Microphone Input Assignments (Microphone Inputs)

Each zone on the system can be assigned to the nearest Microphone Input for Central Station Talk/Listen. Enter 01-04 for each zone on the system to assign it to the nearest microphone input available.

**NOTE:** If section [10] option 2 is enabled all microphones will be active.

## [998] Factory Default Programming

When this section is successfully entered on the PowerSeries panel, all programming in the PC5950 Audio Verification Module will be returned to the factory defaults. Enter **[998][Installer Code][998]** at the system keypad.

**Hardware Default:** A hardware default can be performed if the installer code is lost by powering up the system with the GRN terminal shorted to the Bell In terminal.

### PC5950 v1.0 Programming Worksheets - Keybus Mode

#### [04] Call-back/Recovery Window Duration

Valid entries are 01-09 minutes, 00 to disable     Default **05**

#### [05] Call-back Acknowledge Code

Valid entries are 000000-999999           Default **999999**

#### [06] Answering Machine Bypass

**No. of Rings** (Valid entries are 01-09, 00 to disable)     Default **00**

**NOTE:** A minimum 6-second delay is required before call-back.

**NOTE:** Program this section with a value greater than 2 for DLS Double-call support.

#### [07] Answering Machine Bypass Double-call Timer

Valid entries are 01-99 seconds     Default **30**

#### [08] Number of Rings to Answer On

**# of Rings** (Valid entries are 01-09, 00 to disable)     Default **00**

#### [10] Audio Options (✓ Denotes Option Default)

| Opt | Option ON  | Option OFF  |
|-----|--|---|
| 1   | <input type="checkbox"/> Future Use                                  | <input checked="" type="checkbox"/>                         |
| 2   | <input checked="" type="checkbox"/> Listen to all zones when on-line | <input type="checkbox"/> Listen to zones in alarm only      |
| 3   | <input type="checkbox"/> Bell Follower Enabled                       | <input checked="" type="checkbox"/> Bell Follower Disabled  |
| 4   | <input type="checkbox"/> Tamper Output Active Hi                     | <input checked="" type="checkbox"/> Tamper Output Active Lo |
| 5   | <input checked="" type="checkbox"/> Hang-up Auto-detect Enabled      | <input type="checkbox"/> Hang-up Auto-detect Disabled       |
| 6   | <input type="checkbox"/> User Call-in Enabled                        | <input checked="" type="checkbox"/> User Call-in Disabled   |
| 7   | <input type="checkbox"/> Future Use                                  | <input checked="" type="checkbox"/>                         |
| 8   | <input type="checkbox"/> Manual Bell Shut-off                        | <input checked="" type="checkbox"/> Auto Bell Shut-off      |

**NOTE:** All microphones are set to listen-in by default.

#### [14] Audio Station Tamper Options

| Opt | Option ON  | Option OFF                                   |
|-----|--|--|
| 1   | <input type="checkbox"/> Audio Station #1 Tamper Enabled | <input checked="" type="checkbox"/> Disabled |
| 2   | <input type="checkbox"/> Audio Station #2 Tamper Enabled | <input checked="" type="checkbox"/> Disabled |
| 3   | <input type="checkbox"/> Audio Station #3 Tamper Enabled | <input checked="" type="checkbox"/> Disabled |
| 4   | <input type="checkbox"/> Audio Station #4 Tamper Enabled | <input checked="" type="checkbox"/> Disabled |
| 5-8 | <input type="checkbox"/> Future Use                      | <input checked="" type="checkbox"/>          |

**[30] 1st Audio Control Options** (✓ Denotes Option Default)

| <b>Opt</b> | <b>Option ON</b>                              | <b>Option OFF</b>                            |
|------------|---|--|
| 1          | <input type="checkbox"/> Zone 1 Alarm Enabled | <input checked="" type="checkbox"/> Disabled |
| 2          | <input type="checkbox"/> Zone 2 Alarm Enabled | <input checked="" type="checkbox"/> Disabled |
| 3          | <input type="checkbox"/> Zone 3 Alarm Enabled | <input checked="" type="checkbox"/> Disabled |
| 4          | <input type="checkbox"/> Zone 4 Alarm Enabled | <input checked="" type="checkbox"/> Disabled |
| 5          | <input type="checkbox"/> Zone 5 Alarm Enabled | <input checked="" type="checkbox"/> Disabled |
| 6          | <input type="checkbox"/> Zone 6 Alarm Enabled | <input checked="" type="checkbox"/> Disabled |
| 7          | <input type="checkbox"/> Zone 7 Alarm Enabled | <input checked="" type="checkbox"/> Disabled |
| 8          | <input type="checkbox"/> Zone 8 Alarm Enabled | <input checked="" type="checkbox"/> Disabled |

**[31] 2nd Audio Control Options** (✓ Denotes Option Default)

| <b>Opt</b> | <b>Option ON</b>                               | <b>Option OFF</b>                            |
|------------|--|--|
| 1          | <input type="checkbox"/> Zone 9 Alarm Enabled  | <input checked="" type="checkbox"/> Disabled |
| 2          | <input type="checkbox"/> Zone 10 Alarm Enabled | <input checked="" type="checkbox"/> Disabled |
| 3          | <input type="checkbox"/> Zone 11 Alarm Enabled | <input checked="" type="checkbox"/> Disabled |
| 4          | <input type="checkbox"/> Zone 12 Alarm Enabled | <input checked="" type="checkbox"/> Disabled |
| 5          | <input type="checkbox"/> Zone 13 Alarm Enabled | <input checked="" type="checkbox"/> Disabled |
| 6          | <input type="checkbox"/> Zone 14 Alarm Enabled | <input checked="" type="checkbox"/> Disabled |
| 7          | <input type="checkbox"/> Zone 15 Alarm Enabled | <input checked="" type="checkbox"/> Disabled |
| 8          | <input type="checkbox"/> Zone 16 Alarm Enabled | <input checked="" type="checkbox"/> Disabled |

**[32] 3rd Audio Control Options** (✓ Denotes Option Default)

| <b>Opt</b> | <b>Option ON</b>                               | <b>Option OFF</b>                            |
|------------|--|--|
| 1          | <input type="checkbox"/> Zone 17 Alarm Enabled | <input checked="" type="checkbox"/> Disabled |
| 2          | <input type="checkbox"/> Zone 18 Alarm Enabled | <input checked="" type="checkbox"/> Disabled |
| 3          | <input type="checkbox"/> Zone 19 Alarm Enabled | <input checked="" type="checkbox"/> Disabled |
| 4          | <input type="checkbox"/> Zone 20 Alarm Enabled | <input checked="" type="checkbox"/> Disabled |
| 5          | <input type="checkbox"/> Zone 21 Alarm Enabled | <input checked="" type="checkbox"/> Disabled |
| 6          | <input type="checkbox"/> Zone 22 Alarm Enabled | <input checked="" type="checkbox"/> Disabled |
| 7          | <input type="checkbox"/> Zone 23 Alarm Enabled | <input checked="" type="checkbox"/> Disabled |
| 8          | <input type="checkbox"/> Zone 24 Alarm Enabled | <input checked="" type="checkbox"/> Disabled |

**[33] 4th Audio Control Options** (✓ Denotes Option Default)

| <b>Opt</b> | <b>Option ON</b>                               | <b>Option OFF</b>                            |
|------------|--|--|
| 1          | <input type="checkbox"/> Zone 25 Alarm Enabled | <input checked="" type="checkbox"/> Disabled |
| 2          | <input type="checkbox"/> Zone 26 Alarm Enabled | <input checked="" type="checkbox"/> Disabled |
| 3          | <input type="checkbox"/> Zone 27 Alarm Enabled | <input checked="" type="checkbox"/> Disabled |
| 4          | <input type="checkbox"/> Zone 28 Alarm Enabled | <input checked="" type="checkbox"/> Disabled |
| 5          | <input type="checkbox"/> Zone 29 Alarm Enabled | <input checked="" type="checkbox"/> Disabled |
| 6          | <input type="checkbox"/> Zone 30 Alarm Enabled | <input checked="" type="checkbox"/> Disabled |
| 7          | <input type="checkbox"/> Zone 31 Alarm Enabled | <input checked="" type="checkbox"/> Disabled |
| 8          | <input type="checkbox"/> Zone 32 Alarm Enabled | <input checked="" type="checkbox"/> Disabled |

**[34] 5th Audio Control Options** (✓ Denotes Option Default)

| <b>Opt</b> | <b>Option ON</b>                               | <b>Option OFF</b>                            |
|------------|--|--|
| 1          | <input type="checkbox"/> Zone 33 Alarm Enabled | <input checked="" type="checkbox"/> Disabled |
| 2          | <input type="checkbox"/> Zone 34 Alarm Enabled | <input checked="" type="checkbox"/> Disabled |
| 3          | <input type="checkbox"/> Zone 35 Alarm Enabled | <input checked="" type="checkbox"/> Disabled |

- |   |  |  |
|---|--|--|
| 4 | <input type="checkbox"/> Zone 36 Alarm Enabled | <input checked="" type="checkbox"/> Disabled |
| 5 | <input type="checkbox"/> Zone 37 Alarm Enabled | <input checked="" type="checkbox"/> Disabled |
| 6 | <input type="checkbox"/> Zone 38 Alarm Enabled | <input checked="" type="checkbox"/> Disabled |
| 7 | <input type="checkbox"/> Zone 39 Alarm Enabled | <input checked="" type="checkbox"/> Disabled |
| 8 | <input type="checkbox"/> Zone 40 Alarm Enabled | <input checked="" type="checkbox"/> Disabled |

**[35] 6th Audio Control Options (✓ Denotes Option Default)**

- | Opt | Option ON                                      | Option OFF                                   |
|-----|--|--|
| 1   | <input type="checkbox"/> Zone 41 Alarm Enabled | <input checked="" type="checkbox"/> Disabled |
| 2   | <input type="checkbox"/> Zone 42 Alarm Enabled | <input checked="" type="checkbox"/> Disabled |
| 3   | <input type="checkbox"/> Zone 43 Alarm Enabled | <input checked="" type="checkbox"/> Disabled |
| 4   | <input type="checkbox"/> Zone 44 Alarm Enabled | <input checked="" type="checkbox"/> Disabled |
| 5   | <input type="checkbox"/> Zone 45 Alarm Enabled | <input checked="" type="checkbox"/> Disabled |
| 6   | <input type="checkbox"/> Zone 46 Alarm Enabled | <input checked="" type="checkbox"/> Disabled |
| 7   | <input type="checkbox"/> Zone 47 Alarm Enabled | <input checked="" type="checkbox"/> Disabled |
| 8   | <input type="checkbox"/> Zone 48 Alarm Enabled | <input checked="" type="checkbox"/> Disabled |

**[36] 7th Audio Control Options (✓ Denotes Option Default)**

- | Opt | Option ON                                      | Option OFF                                   |
|-----|--|--|
| 1   | <input type="checkbox"/> Zone 49 Alarm Enabled | <input checked="" type="checkbox"/> Disabled |
| 2   | <input type="checkbox"/> Zone 50 Alarm Enabled | <input checked="" type="checkbox"/> Disabled |
| 3   | <input type="checkbox"/> Zone 51 Alarm Enabled | <input checked="" type="checkbox"/> Disabled |
| 4   | <input type="checkbox"/> Zone 52 Alarm Enabled | <input checked="" type="checkbox"/> Disabled |
| 5   | <input type="checkbox"/> Zone 53 Alarm Enabled | <input checked="" type="checkbox"/> Disabled |
| 6   | <input type="checkbox"/> Zone 54 Alarm Enabled | <input checked="" type="checkbox"/> Disabled |
| 7   | <input type="checkbox"/> Zone 55 Alarm Enabled | <input checked="" type="checkbox"/> Disabled |
| 8   | <input type="checkbox"/> Zone 56 Alarm Enabled | <input checked="" type="checkbox"/> Disabled |

**[37] 8th Audio Control Options (✓ Denotes Option Default)**

- | Opt | Option ON                                      | Option OFF                                   |
|-----|--|--|
| 1   | <input type="checkbox"/> Zone 57 Alarm Enabled | <input checked="" type="checkbox"/> Disabled |
| 2   | <input type="checkbox"/> Zone 58 Alarm Enabled | <input checked="" type="checkbox"/> Disabled |
| 3   | <input type="checkbox"/> Zone 59 Alarm Enabled | <input checked="" type="checkbox"/> Disabled |
| 4   | <input type="checkbox"/> Zone 60 Alarm Enabled | <input checked="" type="checkbox"/> Disabled |
| 5   | <input type="checkbox"/> Zone 61 Alarm Enabled | <input checked="" type="checkbox"/> Disabled |
| 6   | <input type="checkbox"/> Zone 62 Alarm Enabled | <input checked="" type="checkbox"/> Disabled |
| 7   | <input type="checkbox"/> Zone 63 Alarm Enabled | <input checked="" type="checkbox"/> Disabled |
| 8   | <input type="checkbox"/> Zone 64 Alarm Enabled | <input checked="" type="checkbox"/> Disabled |

**[38] 9th Audio Control Options (✓ Denotes Option Default)**

- | Opt | Option ON  | Option OFF                                   |
|-----|--|--|
| 1   | <input type="checkbox"/> Tamper Enabled                  | <input checked="" type="checkbox"/> Disabled |
| 2   | <input type="checkbox"/> Openings & Closings Enabled     | <input checked="" type="checkbox"/> Disabled |
| 3   | <input type="checkbox"/> A Key Alarm Enabled             | <input checked="" type="checkbox"/> Disabled |
| 4   | <input type="checkbox"/> P Key Alarm Enabled             | <input checked="" type="checkbox"/> Disabled |
| 5   | <input type="checkbox"/> Duress Alarm Enabled            | <input checked="" type="checkbox"/> Disabled |
| 6   | <input type="checkbox"/> Zone Expander Supervisory Alarm | <input checked="" type="checkbox"/> Disabled |
| 7   | <input type="checkbox"/> Opening After Alarm Enabled     | <input checked="" type="checkbox"/> Disabled |
| 8   | <input type="checkbox"/> Future Use                      | <input checked="" type="checkbox"/> Disabled |



**[40] Microphone Input Assignments, Zones 1-8**

| (Enter nearest microphone input number (01-04, 00=Not Used) |      | Default |
|---|------|---------|
| Zone 1 Microphone Input Assignment                          | ____ | 00      |
| Zone 2 Microphone Input Assignment                          | ____ | 00      |
| Zone 3 Microphone Input Assignment                          | ____ | 00      |
| Zone 4 Microphone Input Assignment                          | ____ | 00      |
| Zone 5 Microphone Input Assignment                          | ____ | 00      |
| Zone 6 Microphone Input Assignment                          | ____ | 00      |
| Zone 7 Microphone Input Assignment                          | ____ | 00      |
| Zone 8 Microphone Input Assignment                          | ____ | 00      |

**[41] Microphone Input Assignments, Zones 9-16**

| (Enter nearest microphone input number (01-04, 00=Not Used) |      | Default |
|---|------|---------|
| Zone 9 Microphone Input Assignment                          | ____ | 00      |
| Zone 10 Microphone Input Assignment                         | ____ | 00      |
| Zone 11 Microphone Input Assignment                         | ____ | 00      |
| Zone 12 Microphone Input Assignment                         | ____ | 00      |
| Zone 13 Microphone Input Assignment                         | ____ | 00      |
| Zone 14 Microphone Input Assignment                         | ____ | 00      |
| Zone 15 Microphone Input Assignment                         | ____ | 00      |
| Zone 16 Microphone Input Assignment                         | ____ | 00      |

**[42] Microphone Input Assignments, Zones 17-24**

| (Enter nearest microphone input number (01-04, 00=Not Used) |      | Default |
|---|------|---------|
| Zone 17 Microphone Input Assignment                         | ____ | 00      |
| Zone 18 Microphone Input Assignment                         | ____ | 00      |
| Zone 19 Microphone Input Assignment                         | ____ | 00      |
| Zone 20 Microphone Input Assignment                         | ____ | 00      |
| Zone 21 Microphone Input Assignment                         | ____ | 00      |
| Zone 22 Microphone Input Assignment                         | ____ | 00      |
| Zone 23 Microphone Input Assignment                         | ____ | 00      |
| Zone 24 Microphone Input Assignment                         | ____ | 00      |

**[43] Microphone Input Assignments, Zones 25-32**

| (Enter nearest microphone input number (01-04, 00=Not Used) |      | Default |
|---|------|---------|
| Zone 25 Microphone Input Assignment                         | ____ | 00      |
| Zone 26 Microphone Input Assignment                         | ____ | 00      |
| Zone 27 Microphone Input Assignment                         | ____ | 00      |
| Zone 28 Microphone Input Assignment                         | ____ | 00      |
| Zone 29 Microphone Input Assignment                         | ____ | 00      |
| Zone 30 Microphone Input Assignment                         | ____ | 00      |
| Zone 31 Microphone Input Assignment                         | ____ | 00      |
| Zone 32 Microphone Input Assignment                         | ____ | 00      |

**[44] Microphone Input Assignments, Zones 33-40**

| (Enter nearest microphone input number (01-04, 00=Not Used) |      | Default |
|---|------|---------|
| Zone 33 Microphone Input Assignment                         | ____ | 00      |
| Zone 34 Microphone Input Assignment                         | ____ | 00      |
| Zone 35 Microphone Input Assignment                         | ____ | 00      |
| Zone 36 Microphone Input Assignment                         | ____ | 00      |
| Zone 37 Microphone Input Assignment                         | ____ | 00      |

|                                     |     |    |
|-------------------------------------|-----|----|
| Zone 38 Microphone Input Assignment | _ _ | 00 |
| Zone 39 Microphone Input Assignment | _ _ | 00 |
| Zone 40 Microphone Input Assignment | _ _ | 00 |

**[45] Microphone Input Assignments, Zones 41-48**

|   |     |         |
|---|-----|---------|
| (Enter nearest microphone input number (01-04, 00=Not Used) |     | Default |
| Zone 41 Microphone Input Assignment                         | _ _ | 00      |
| Zone 42 Microphone Input Assignment                         | _ _ | 00      |
| Zone 43 Microphone Input Assignment                         | _ _ | 00      |
| Zone 44 Microphone Input Assignment                         | _ _ | 00      |
| Zone 45 Microphone Input Assignment                         | _ _ | 00      |
| Zone 46 Microphone Input Assignment                         | _ _ | 00      |
| Zone 47 Microphone Input Assignment                         | _ _ | 00      |
| Zone 48 Microphone Input Assignment                         | _ _ | 00      |

**[46] Microphone Input Assignments, Zones 49-56**

|   |     |         |
|---|-----|---------|
| (Enter nearest microphone input number (01-04, 00=Not Used) |     | Default |
| Zone 49 Microphone Input Assignment                         | _ _ | 00      |
| Zone 50 Microphone Input Assignment                         | _ _ | 00      |
| Zone 51 Microphone Input Assignment                         | _ _ | 00      |
| Zone 52 Microphone Input Assignment                         | _ _ | 00      |
| Zone 53 Microphone Input Assignment                         | _ _ | 00      |
| Zone 54 Microphone Input Assignment                         | _ _ | 00      |
| Zone 55 Microphone Input Assignment                         | _ _ | 00      |
| Zone 56 Microphone Input Assignment                         | _ _ | 00      |

**[47] Microphone Input Assignments, Zones 57-64**

|   |     |         |
|---|-----|---------|
| (Enter nearest microphone input number (01-04, 00=Not Used) |     | Default |
| Zone 57 Microphone Input Assignment                         | _ _ | 00      |
| Zone 58 Microphone Input Assignment                         | _ _ | 00      |
| Zone 59 Microphone Input Assignment                         | _ _ | 00      |
| Zone 60 Microphone Input Assignment                         | _ _ | 00      |
| Zone 61 Microphone Input Assignment                         | _ _ | 00      |
| Zone 62 Microphone Input Assignment                         | _ _ | 00      |
| Zone 63 Microphone Input Assignment                         | _ _ | 00      |
| Zone 64 Microphone Input Assignment                         | _ _ | 00      |

**[998] Factory Default Programming**

[998][Installer Code][998] Restores all programming to defaults above

## 4.2 Programming - Universal Mode

To access the Universal Programming of the PC5950 call the module from an external telephone line (by default full time call-back is active and set to one ring). The module will sound an ACK to indicate initial access. Once the installer's code (5555 by default) has been entered, you will hear a set of tones. Enter the 2-digit option number to be programmed (refer to the table below). The module will sound 3 low beeps to acknowledge the section has been entered. No feedback is given on the default value programmed. Enter the new programming values. Two low-high beeps are sounded to acknowledge that the data is valid. Press [\*] to save the settings and return to the main menu, the module will sound 3 low beeps. Pressing any key other than [\*] will cancel the changes and return to the main menu, the module will sound a NACK. To exit programming enter section 00, press [\*] and the module will hang up.

**NOTE: The PC5950 default setting is to answer the telephone on the first ring. See option [16] to disable this feature or change the number of rings.**

### Programming Options - Universal Mode

| Option  | Description   |  |                    |          |   |   |   |   |   |  |   |     |   |   |     |   |
|---------|---|--|--------------------|----------|---|---|---|---|---|--|---|-----|---|---|-----|---|
|         | ✓ Indicates the default setting   |  |                    |          |   |   |   |   |   |  |   |     |   |   |     |   |
| 01      | <p><b>Hard-trip/Auto-trip</b></p> <p>1 <b>Hard-trip:</b> Use this setting if the control panel provides a kiss-off (2-way activation)</p> <p>✓ 2 <b>Auto-trip:</b> Use this setting if the control panel does <b>not</b> provide a kiss-off</p>   |  |                    |          |   |   |   |   |   |  |   |     |   |   |     |   |
| 02      | <p>✓ 1 <b>Activate immediately/1-Ring Call-back mode</b><br/>Trigger Input (hard-wired or auto-trip), module seizes phone line immediately</p> <p>2 Trigger Input (hard-wired or auto-trip), module enables 1-ring call back window.</p> <p style="text-align: center;"><b>Central Monitoring Station (CMS) Modes</b></p> <table border="1" style="margin-left: auto; margin-right: auto;"> <thead> <tr> <th>Setting</th> <th>Window (See Opt 4)</th> <th>Activity</th> </tr> </thead> <tbody> <tr> <td>1</td> <td>0</td> <td>Activate CMS immediately, no CMS call-in window, no CMS call-in recovery window</td> </tr> <tr> <td>2</td> <td>0</td> <td>Does not activate CMS immediately, no CMS call-in window, no CMS call-in recovery window (no CMS mode)</td> </tr> <tr> <td>1</td> <td>1-9</td> <td>Activate CMS immediately, no CMS-call-in window, CMS call-in recovery window (typical method)</td> </tr> <tr> <td>2</td> <td>1-9</td> <td>Does not activate CMS immediately, CMS call-in window after alarm, CMS call-in recovery window.</td> </tr> </tbody> </table> <p><b>NOTE: The user can call-in when the CMS or CMS window is not active.</b><br/> <b>NOTE: The CMS call-back window is activated after an alarm. The CMS call-back recovery window is activated when a CMS session is terminated abnormally (i.e., not ended by the CMS by pressing the end key (99) or time-out (forgot to Extend). The 2 call-back windows use the same programmable timer.</b></p> | Setting  | Window (See Opt 4) | Activity | 1 | 0 | Activate CMS immediately, no CMS call-in window, no CMS call-in recovery window | 2 | 0 | Does not activate CMS immediately, no CMS call-in window, no CMS call-in recovery window (no CMS mode) | 1 | 1-9 | Activate CMS immediately, no CMS-call-in window, CMS call-in recovery window (typical method) | 2 | 1-9 | Does not activate CMS immediately, CMS call-in window after alarm, CMS call-in recovery window. |
| Setting | Window (See Opt 4)  | Activity   |                    |          |   |   |   |   |   |  |   |     |   |   |     |   |
| 1       | 0   | Activate CMS immediately, no CMS call-in window, no CMS call-in recovery window                        |                    |          |   |   |   |   |   |  |   |     |   |   |     |   |
| 2       | 0   | Does not activate CMS immediately, no CMS call-in window, no CMS call-in recovery window (no CMS mode) |                    |          |   |   |   |   |   |  |   |     |   |   |     |   |
| 1       | 1-9   | Activate CMS immediately, no CMS-call-in window, CMS call-in recovery window (typical method)          |                    |          |   |   |   |   |   |  |   |     |   |   |     |   |
| 2       | 1-9   | Does not activate CMS immediately, CMS call-in window after alarm, CMS call-in recovery window.        |                    |          |   |   |   |   |   |  |   |     |   |   |     |   |
| 04      | <p>✓ 5 <b>Call-back/Recovery Window Duration</b><br/>Selects the number of minutes (1-9) the recovery window remains open (See option 2) 0 = disabled</p>   |  |                    |          |   |   |   |   |   |  |   |     |   |   |     |   |
| 05      | <p>✓ <b>999999 Call-back Acknowledge Code</b><br/>6-digit programmable code (000000-999999) that allows access in Call-back mode <b>DSC recommends that this code differ from the User and Installer codes</b></p>  |  |                    |          |   |   |   |   |   |  |   |     |   |   |     |   |
| 06      | <p><b>Hang-up Auto-detect</b></p> <p>✓ 1 System Hangs up if disconnected.</p> <p>2 System remains on-line until time-out</p>  |  |                    |          |   |   |   |   |   |  |   |     |   |   |     |   |
| 07      | <p><b>Trigger Input Active Level</b></p> <p>1 Trigger enabled when trigger input <b>HI</b> (open)</p> <p>✓ 2 Trigger enabled when trigger input <b>Lo</b> (switched to ground)</p>  |  |                    |          |   |   |   |   |   |  |   |     |   |   |     |   |

## Programming Options - Universal Mode

| Option | Description  |
|--------|--|
| 08     | <p><b>Enable Input Active Level</b></p> <p>1 Trigger enabled when Enable input <b>HI</b> (open)<br/>                     ✓ 2 Trigger enabled when Enable input <b>Lo</b> (switched to ground)</p>  |
| 09     | <p><b>Bell Input Active Level</b></p> <p>✓ 1 Trigger enabled when Bell input <b>HI</b> (open)<br/>                     2 Trigger enabled when Bell input <b>Lo</b> (switched to ground)<br/> <b>NOTE:</b> If the bell is floating, Bell Input should be set to Open and Bell Follower should not be used.</p>                                    |
| 10     | <p><b>Trigger Enable Required</b></p> <p>✓ 1 <b>Auto-trip:</b> trigger by Bell only. <b>Hard Trip:</b> trigger enabled by Bell <b>and</b> GRN<br/>                     2 <b>Auto-trip:</b> trigger by Bell or enable. <b>Hard Trip:</b> trigger enabled by Bell <b>or</b> GRN</p>  |
| 14     | <p>✓ 0 <b>Answering Machine Bypass</b></p> <p>Selects the number of rings (1-9) required on first call for hang up and call-back. Unit always answers on first ring of second call.<br/> <b>NOTE: A minimum 6 second delay is required before call-back.</b><br/>                     0 = disabled</p>   |
| 15     | <p>✓ 30 <b>Answering Machine Bypass Double-call Timer</b></p> <p>Selects the maximum delay (01-99 seconds) between calls on double-call (from last ring of first call).</p>  |
| 16     | <p>✓ 1 <b>Full-time Call-back Number of Rings</b></p> <p>Selects the number of rings (1-9) to receive before answering User or Installer Call-up. CMS Call-back and Recovery always answer on first ring.<br/> <b>NOTE: If Option 14 and Option 16 are set to 0, module will answer on first ring.</b><br/>                     0 = Disabled</p> |
| 17     | <p><b>User Call-in</b></p> <p>✓ 1 Allows User code to initiate an audio session from a call-in.<br/>                     2 Does <b>not</b> allow User code to initiate an audio session from a call-in.</p>  |
| 20     | <p>✓ 5555 <b>Installer Code</b></p> <p>4-digit programmable code (0000-9999) that allows access by Installer or Central Station.<br/> <b>DSC recommends that this code is different from the User and Call-back acknowledge codes. If set to the same value as the User Code, only User access will be granted.</b></p>                          |
| 21     | <p><b>Audio Station 1 Tamper Option</b></p> <p>1 Audio Station 1 tamper enabled.<br/>                     ✓ 2 Audio Station 1 tamper disabled.</p>   |
| 22     | <p><b>Audio Station 2 Tamper Option</b></p> <p>1 Audio Station 2 tamper enabled.<br/>                     ✓ 2 Audio Station 2 tamper disabled.</p>   |
| 23     | <p><b>Audio Station 3 Tamper Option</b></p> <p>1 Audio Station 3 tamper enabled.<br/>                     ✓ 2 Audio Station 3 tamper disabled.</p>   |
| 24     | <p><b>Audio Station 4 Tamper Option</b></p> <p>1 Audio Station 4 tamper enabled.<br/>                     ✓ 2 Audio Station 4 tamper disabled.</p>   |
| 25     | <p><b>Tamper Out Terminal Active Level</b></p> <p>1 Tamper on any microphone will switch TMP terminal from GND to Open.<br/>                     ✓ 2 Tamper on any microphone will switch TMP terminal from Open to GND.</p>   |

## Programming Options - Universal Mode

| Option | Description   |
|--------|---|
| 26     | <p><b>Bell Follower</b></p> <p>1 Speaker emits alarm in the cadence detected on the Bell Input.</p> <p>✓ 2 Speaker does NOT sound alarm.</p>  |
| 27     | <p><b>Bell Control</b></p> <p>When enabled (1 is programmed) a DTMF digit is required to enter 2-way audio and turn off the bell.</p> <p>1 Manual bell shut-off</p> <p>✓ 2 Auto bell shut-off</p> |
| 99     | <p><b>[Installer Code][99]</b></p> <p>Entering [99][Installer Code][99] will reset the unit to factory default programming.</p>   |

### 4.3 User Code Programming

User code programming is accessed by entering [\*][5] during a User Call-in session.

Refer to the **PC5950 Audio Verification Module User Guide** (part number 29007322) for details.

## Limited Warranty

DSC warrants that for a period of one year from the date of purchase, the product shall be free of defects in material and workmanship under normal use and that in fulfillment of any breach of such warranty, DSC shall, at its option, repair or replace the defective equipment upon return of the equipment to its repair depot. This warranty applies only to defects in materials and workmanship and not to damage incurred in shipping or handling, or damage due to causes beyond the control of DSC, such as lightning, excessive voltage, mechanical shock, water damage or damage arising out of abuse, alteration or improper application of the product.

The foregoing warranty shall apply only to the original buyer, and shall be in lieu of any and all other warranties, whether expressed or implied, and of all other obligations or liabilities on the part of DSC. This warranty contains the entire warranty. DSC neither assumes responsibility for, nor authorizes any other person purporting to act on its behalf, to modify or to change this warranty, nor to assume for it any other warranty or liability concerning this product.

In no event shall DSC be liable for any direct, indirect or consequential damages, loss of anticipated profits, loss of time or any other losses incurred by the buyer in connection with the purchase, installation or operation or failure of this product.

### IMPORTANT!

DSC recommends that the entire system be completely tested on a regular basis. However, despite frequent testing, and due to but not limited to criminal tampering or electrical disruption, it is possible for this product to fail to perform as expected.

DSC erklærer herved at denne komponenten overholder alle vigtige krav samt andre bestemmelser gitt i direktiv 1999/5/EC.

Por este meio, a DSC, declara que este equipamento está em conformidade com os requisitos essenciais e outras determinações relevantes da Directiva 1999/5/EC.

'DSC bekräftar härmed att denna apparat uppfyller de väsentliga kraven och andra relevanta bestämmelser i Direktivet 1999/5/EC'.

Con la presente la Digital Security Controls dichiara che questo prodotto è conforme ai requisiti essenziali ed altre disposizioni rilevanti relative alla Direttiva 1999/05/CE.

Por la presente, DSC declara que este equipo está en conformidad con los requisitos esenciales y otros requisitos relevantes de la Directiva 1999/5/EC.

Hierdurch erklärt DSC, daß dieses Gerät den erforderlichen Bedingungen und Voraussetzungen der Richtlinie 1999/5/EC entspricht.

'Δια του παρόντος, η DSC, δηλώνει ότι αυτή η συσκευή είναι σύμφωνη με τις ουσιαστικές απαιτήσεις και με όλες τις άλλες σχετικές αναφορές της Οδηγίας 1999/5/EC'.

Hierbij verklaart DSC dat dit toestel in overeenstemming is met de eisen en bepalingen van richtlijn 1999/5/EC.

Par la présente, DSC déclare que cet article est conforme aux exigences essentielles et autres pertinentes stipulations de la directive 1999/5/EC.

DSC vakuuttaa laitteen täyttävän direktiivin 1999/5/EC olennaiset vaatimukset.

Hereby, DSC, declares that this device is in compliance with the essential requirements and other relevant provisions of Directive 1999/5/EC.

**The complete R & TTE Declaration of Conformity can be found at [www.dsc.com/intl/rtdirect.htm](http://www.dsc.com/intl/rtdirect.htm).**



**DSC**

©2008 Digital Security Controls.

Toronto, Canada • [www.dsc.com](http://www.dsc.com)

Technical Support: 1-800-387-3630 (Canada & U.S.) or 905-760-3036