

# PC5900

## Audio Verification Module

*For use with PowerSeries control panels*

### *Installation Manual*

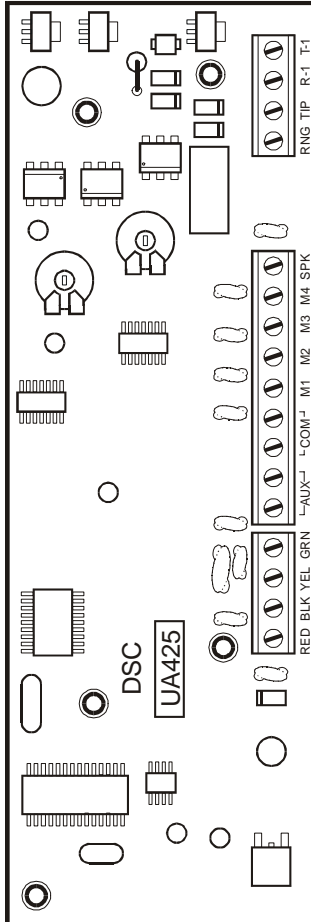

**WARNING:** This document contains information on limitations regarding product use and function and information on the limitations as to liability of the manufacturer. Read the entire manually carefully.

## FCC COMPLIANCE STATEMENT

**CAUTION:** Changes or modifications not expressly approved by Digital Security Controls Ltd. could void your authority to use this equipment.

This equipment has been tested and found to comply with the limits for a Class B digital device, pursuant to Part 15 of the FCC Rules. These limits are designed to provide reasonable protection against harmful interference in a residential installation. This equipment generates, uses and can radiate radio frequency energy and, if not installed and used in accordance with the instructions, may cause harmful interference to radio communications. However, there is no guarantee that interference will not occur in a particular installation. If this equipment does cause harmful interference to radio or television reception, which can be determined by turning the equipment off and on, the user is encouraged to try to correct the interference by one or more of the following measures:

Re-orient the receiving antenna.

Increase the separation between the equipment and receiver.

Connect the equipment into an outlet on a circuit different from that to which the receiver is connected.

Consult the dealer or an experienced radio/television technician for help.

The user may find the following booklet prepared by the FCC useful: "How to Identify and Resolve Radio/Television Interference Problems". This booklet is available from the U.S. Government Printing Office, Washington D.C. 20402, Stock # 004-000-00345-4.

### IMPORTANT INFORMATION

This equipment complies with Part 68 of the FCC Rules and the requirements adopted by the ACTA. On the side of this equipment is a label that contains, among other information, a product identifier in the format US:AAAEQ##TXXXX. If requested, this number must be provided to the Telephone Company.

Product identifier: US:F53KX01BPC5900

USOC Jack: RJ-31X

### Telephone Connection Requirements

A plug and jack used to connect this equipment to the premises wiring and telephone network must comply with the applicable FCC Part 68 rules and requirements adopted by the ACTA. A compliant telephone cord and modular plug is provided with this product. It is designed to be connected to a compatible modular jack that is also compliant. See installation instructions for details.

### Ringer Equivalence Number (REN)

The REN is used to determine the number of devices that may be connected to a telephone line. Excessive RENs on a telephone line may result in the devices not ringing in response to an incoming call. In most but not all areas, the sum of RENs should not exceed five (5.0). To be certain of the number of devices that may be connected to a line, as determined by the total RENs, contact the local Telephone Company. For products approved after July 23, 2001, the REN for this product is part of the product identifier that has the format US: AA AEQ##TXXXX. The digits represented by ## are the REN without a decimal point (e.g., 03 is a REN of 0.3). For earlier products, the REN is separately shown on the label.

### IC: 160A -PC5900

**NOTICE:** This equipment meets the applicable Industry Canada Terminal Equipment Technical Specifications. This is confirmed by the registration number. The abbreviation, IC, before the registration number signifies that registration was performed based on a Declaration of Conformity indicating that Industry Canada technical specifications were met. It does not imply that Industry Canada approved the equipment.

**NOTICE:** The Ringer Equivalence Number (REN) for this terminal equipment is 0.1. The REN assigned to each terminal equipment provides an indication of the maximum number of terminals allowed to be connected to a telephone interface. The termination on an interface may consist of any combination of devices subject only to the requirement that the sum of the Ringer Equivalence Numbers of all the devices does not exceed 5.

### Incidence of Harm

If this equipment PC5900 causes harm to the telephone network, the telephone company will notify you in advance that temporary discontinuance of service may be required. But if advance notice is not practical, the Telephone Company will notify the customer as soon as possible. Also, you will be advised of your right to file a complaint with the FCC if you believe it is necessary.

### Changes in Telephone Company Equipment or Facilities

The Telephone Company may make changes in its facilities, equipment, operations or procedures that could affect the operation of the equipment. If this happens the Telephone Company will provide advance notice in order for you to make necessary modifications to maintain uninterrupted service.

### Equipment Maintenance Facility

If trouble is experienced with this equipment PC5900, for repair or warranty information, please contact the facility indicated below. If the equipment is causing harm to the telephone network, the Telephone Company may request that you disconnect the equipment until the problem is solved. This equipment is of a type that is not intended to be repaired by the end user.

Simplex Time Recorder Co. 100 Simplex Drive, Westminster MA 01441-0001 USA, Tel: (978) 731-2500

### Additional Information

Connection to party line service is subject to state tariffs. Contact the state public utility commission, public service commission or corporation commission for information.

Alarm dialing equipment must be able to seize the telephone line and place a call in an emergency situation. It must be able to do this even if other equipment (telephone, answering system, computer modem, etc.) already has the telephone line in use. To do so, alarm dialing equipment must be connected to a properly installed RJ-31X jack that is electrically in series with and ahead of all other equipment attached to the same telephone line. Proper installation is depicted in the figure below. If you have any questions concerning these instructions, you should consult your telephone company or a qualified installer about installing the RJ-31X jack and alarm dialing equipment for you.

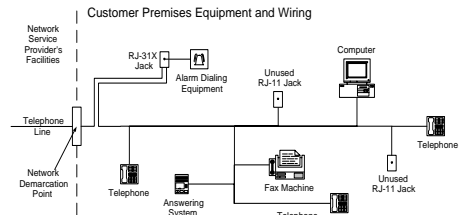

**AVIS :** Le présent matériel est conforme aux spécifications techniques d'Industrie Canada applicables au matériel terminal. Cette conformité est confirmée par le numéro d'enregistrement. Le sigle IC, placé devant le numéro d'enregistrement, signifie que l'enregistrement s'est effectué conformément à une déclaration de conformité et indique que les spécifications techniques d'Industrie Canada ont été respectées. Il n'implique pas qu'Industrie Canada a approuvé le matériel.

**AVIS :** L'indice d'équivalence de la sonnerie (IES) du présent matériel est de 0.1. L'IES assigné à chaque dispositif terminal indique le nombre maximal de terminaux qui peuvent être raccordés à une interface téléphonique. La terminaison d'une interface peut consister en une combinaison quelconque de dispositifs, à la seule condition que la somme d'indices d'équivalence de la sonnerie de tous les dispositifs n'excède pas 5.

# Table of Contents

---

<b>1 Introduction</b>	<b>1</b>
1.1 Specifications	1
1.2 Out of the Box	2
<b>2 Installation</b>	<b>3</b>
2.1 PC5900 Installation	3
2.2 Audio Station Wiring	3
<b>3 Programming</b>	<b>5</b>
<b>4 Programming Worksheets</b>	<b>8</b>
<b>List of Illustrations</b>	
Fig 1 PC5900 Audio Verification Module	1
Fig 2 PC5900 Installation	2
Fig 3 PC5900 Wiring Diagram	4



# 1 Introduction

The PC5900 series Audio Verification Modules provide "Talk / Listen-In" capability for audio verification of alarms. The module permits the central station to monitor up to four microphones and to communicate to the occupants through 2 separate speakers.

The PC5900 series modules connect to PowerSeries control panels via KEYBUS and Telco connection for telephone line connections. The PC5900 Talk/Listen in Options are programmable by the central station operator using telephone keys (1-9), (\*), and (#). See "[20][21] Phone Key and Mode Key Options" on page 5.

The modules mount in the main control panel cabinet (PC5003C/PC4051C) using existing mounting holes (see Figure 3, Installation). All programming can be performed at the system keypad or remotely using DLS software

**Figure 1: PC5900 Audio Verification Module**

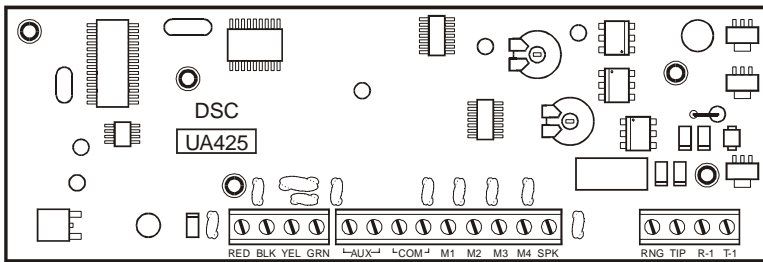

## 1.1 Specifications

Operating voltage (RED, BLK).....	11.5 - 12.5 Vdc (max)
Current Draw (Board Only) .....	50mA (max)
AUX Output .....	11.5 - 12.5 Vdc
PC5904 .....	175 mA
PC5921 .....	50 mA
Range(PC5900 to PC5904).....	500ft (max)
(PC5900 to PC5921) .....	1000ft (max)
Compatible Control Panels .....	PC5010, PC5020

## 1.2 Out of the Box

The PC5900 Kit includes the following:

- 1 PC5900 Audio Verification Module
- 4 Standoffs
- 1 Installation Manual

**Figure 2: Installation**

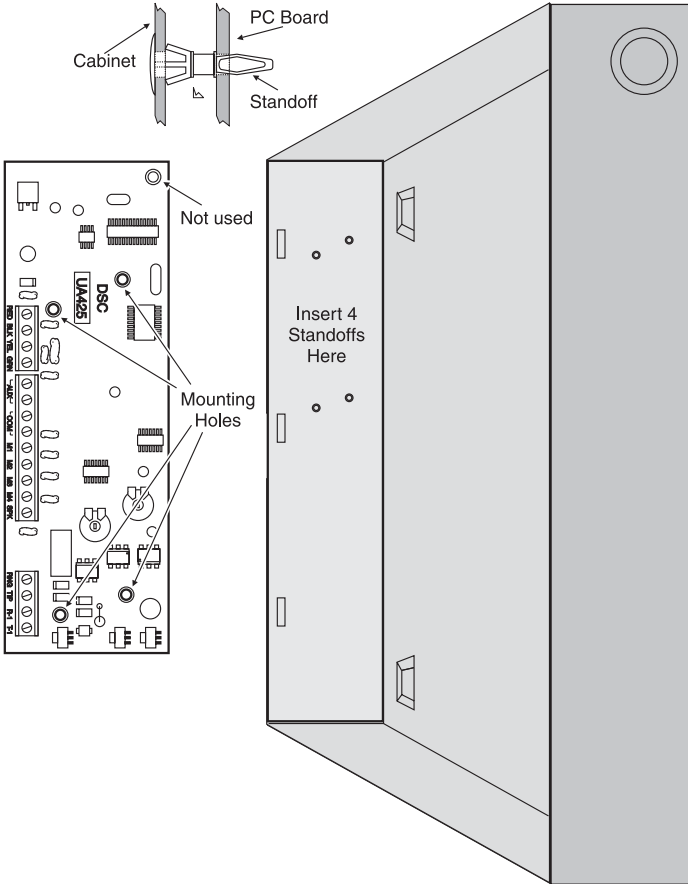

## 2 Installation

### 2.1 PC5900 Installation

The PC5900 module must be installed by SERVICE PERSONNEL ONLY. It must be installed in a metallic cabinet properly grounded. It is the installer's responsibility to ensure such degree of protection for the equipment that NO ACCESS to the TNV circuit is given to the end user. The metallic cabinet must be secured to the building structure before operation. A proper ground connection must be provided for the metal cabinet. Internal wiring must be routed in a manner that prevents:

- excessive strain on wire and on terminal connections
- loosening of terminal connections
- damage to conductor insulation

Follow these steps to install the PC5900 audio interface module and audio stations. Review this section to get an overall understanding of the order of installation. Once this is done, carefully work through each step.

1. Insert the 4 standoffs provided in the position indicated in figure 3. The standoffs will make an audible "click" when positioned correctly.
2. Position the module over the standoffs and press firmly to ensure that the module locks in place.
3. Wire module to the PowerSeries control (keybus), microphones, speakers or Escort as required in accordance with figure 4.

#### Notes

Shielded wire is required for all PC5921/PC5904 wiring to eliminate all noise sources.

Do **NOT** use shielded wire on KEYBUS wire runs. The distributed capacitance of shielded wire can significantly reduce signal quality and range.

4. Program Module as required (see Section 3 Programming).
5. Verify operation.

### 2.2 Audio Station Wiring

Up to 4 audio stations (4 microphones and 2 speakers) can be connected to the PC5900 audio interface module. Each station must be home-run to the interface module via a shielded 22 gauge, 4-conductor cable. Each PC5921 can be up to 1000ft (305m) from the PC5900; each PC5904 can be up to 500ft (152m) from the PC5900.

Connect each station to the audio connections on the PC5900 module as indicated in figure 3. Connect the drain wire of the shield to the COM terminal on the PC5900 module or the black terminal of the station (ensure that the drain wire of the shield does not short anything on the back of the board).

Do **NOT** connect the drain wire of the shield at both ends.

**Figure 3: Wiring Details**

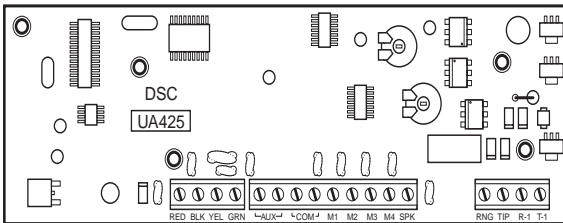
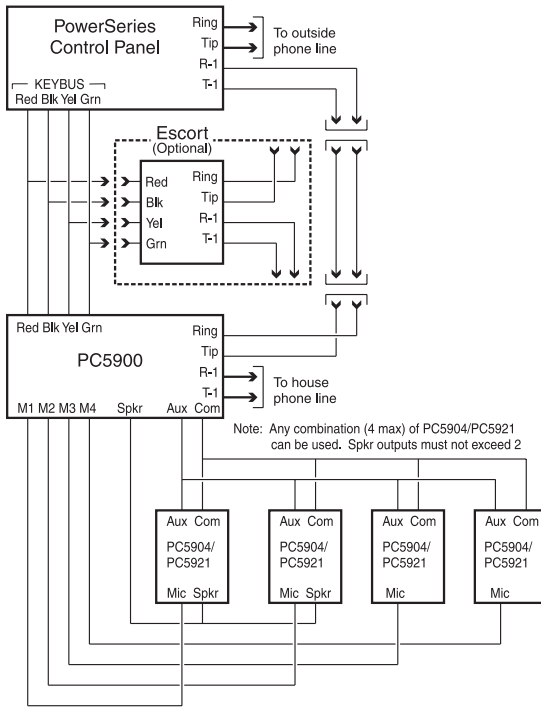

**PC5900 Terminal Connections**

- RED KEYBUS Power
- BLK KEYBUS Ground
- YEL KEYBUS Clock Input
- GRN KEYBUS Data Input / Output
- AUX Auxiliary Power Output AUX (PTC protected locally). Please note that maximum output current is limited by the available current at panel AUX/RED output (refer to the compatible control panel Installation Manual)
- COM Common Ground
- M1 Microphone #1 Input Channel
- M2 Microphone #2 Input Channel
- M3 Microphone #3 Input Channel
- M4 Microphone #4 Input Channel
- SPK Speaker Level Output (supports two DSC PC5904 or PC5921)
- RNG TELCO Ring connection from panel
- TIP TELCO Tip connection from panel
- R-1 TELCO Ring connection to in-house phones
- T-1 TELCO Tip connection to in-house phones

**NOTE: Shielded wire is required for all PC5921/PC5904 wiring**



### 3. Programming

Enter **[\*][8][Installer Code][802]** on the system keypad followed by the desired subsection (listed below) to program options.

**NOTE:** *Numbering of this section corresponds with the numbering of the Programming Worksheets.*

#### **[10] Audio Options**

The Alarm and Talk / Listen option (option 2) will occur for events from all zones and partitions. If option 2 is not selected the Talk/Listen option will only be available when an alarm is activated.

#### **[12] Audio Duration**

This section allows programming of the length of time that the Audio Module will remain on-line with the receiver in Talk / Listen-In. The on-line time can be manually extended by the operator. Valid entries are 00-99 seconds, the default is 90 seconds.

#### **[20][21] Phone Key and Mode Key Options**

This section programs the DTMF key functions received by the PC5900 from the Central Station Operator. Keys [0]-[9], [\*] and [#] are programmable for control of the Talk / Listen-In communication by the Central Station Operator. In addition, a Mode Key can be programmed to add 12 more keys (Mode Key + Key). The available options are as follows:

**[00] Future Use** - The key will not perform any function when pressed during an on-line session.

**[01] High Gain Talk To All Speakers** - This key activates high gain talk to the premises from all speakers.

**[02] For Future Use**

**[03] High Gain Listen To All Active Microphones** - This key activates HIGH gain listen-in from the premises from all currently activated microphones.

**[04] Low Gain Talk To All Speakers** - This key activates LOW gain talk to the premises from all speakers.

**[05] For Future Use**

**[06] Low Gain Listen To All Active Microphones** - This key activates LOW gain listen-in from the premises from all currently activated microphones.

**[07] Extend Time** - Pressing this key extends the session by the time programmed in section [12].

**[08] For Future Use**

**[09] Terminate Session** - When pressed, this key will terminate the Talk / Listen-In session.

**NOTE:** *The **Terminate Session** key should be used by the operator before hanging up during a Talk / Listen-In session.*

**[10] For Future Use**

**[11] Cancel First Keypress** - Pressing this key will cancel the first entry of a 2-digit command.

**[12] Microphone Control (Input)** - This key requires a 1-digit microphone input number (0-5) entry after pressing the key. Once the microphone number has been entered, the input selected is then toggled to either enable or disable the input from the Listen-in session. This allows the Central Station operator the ability to turn off or on the microphone inputs to make a determination (if necessary) as to the ones that are picking up loud background noises and turn them off in order to try and here from the other microphone inputs available. Selecting [0] will turn all of the inputs OFF likewise selecting [5] will turn all of the inputs ON.

**[13] Zone Select** - This key requires a 2-digit zone number (01-64) entry after pressing the key. Once the zone number has been entered the microphone input assigned to that zone is activated for listen-in. If the selected zone does not have a port programmed, the zone select function is cancelled (the module returns to the state it was in before the zone select key was pressed).

**[14] Increment Selected Microphone (Input)** - If the operator does not hear anything initially, they can increment the selected microphone input by pressing this key.

**[15] Decrement Selected Microphone (Input)** - If the operator does not hear anything initially, they can decrement the selected microphone input by pressing this key.

**[15] For Future Use**

**[16] For Future Use**

**[17] Mode Key** - This key allows the operator to toggle to an extended set of commands.

### **[30]-[38] Audio Control Options**

These sections enable / disable specific Zone Alarms that will initiate an audio verification session.

**NOTE:** *If Section [10] Option 2 is enabled, then all microphones will be active and the programming in these sections will be ignored.*

### **[39] Ninth Audio Control Options (Listen-In Options)**

These options enable/disable system events that cause the panel to initiate **Talk / Listen-In** upon completion of the communication handshake. The following system events can be programmed to initiate Talk / Listen-In.

Tampers	N
Openings/Closing	N
[A] Alarm	N
[P] Alarm	N
Duress Alarm	N
Zone Exp. Sup. Alarm	N
Open After Alarm	N

**NOTE:** *The Alarm and Talk / Listen options will occur for events from any partition (entire system).*

## **[40]-[47] Microphone Input Assignments (Microphone Inputs)**

Each zone on the system can be assigned to the nearest Microphone Input for Central Station Talk/Listen. Enter 01-04 for each zone on the system to assign it to the nearest microphone input available.

**NOTE:** *If Section [10] Option 2 is enabled all microphones will be active.*

## **[998] Factory Default Programming**

When this section is successfully entered on the PowerSeries panel, all programming in the PC5900 Audio Verification Module will be returned to the factory defaults.

Enter **[998][Installer Code][998]** at the system keypad.

**[10] Audio Options** (✓ Denotes Option Default)

Opt	Option ON	Option OFF
1	<input type="checkbox"/> Future Use	✓ <input type="checkbox"/>
2	<input type="checkbox"/> Listen to all zones when on-line	✓ <input type="checkbox"/> Listen to zones in alarm only
3-8	<input type="checkbox"/> Future Use	✓ <input type="checkbox"/>

**[12] Audio Duration**

Valid entries are 01-99 seconds Default  
|\_|\_| 90

**[20] Audio Control Telephone Key Programming (See page 5 for details).**

Valid entries are 00-17

[00] Future Use	[09] Terminate Session
[01] High Gain Talk to all Speakers	[10] Future Use
[02] Future Use	[11] Cancel First Keypress
[03] High Gain Listen to all active Microphones	[12] Microphone Control (inputs)
[04] Low Gain Talk to all Speakers	[13] Zone Select (01-64)
[05] Future Use	[14] Increment selected Microphone input
[06] Low Gain Listen to all active Microphones	[15] Decrement selected Microphone input
[07] Extend Time	[16] Future Use
[08] Future Use	[17] Mode Key

	<i>Default</i>		<i>Default</i>
[1] Key  _ _ _	01	[7] Key  _ _ _	07
[2] Key  _ _ _	00	[8] Key  _ _ _	00
[3] Key  _ _ _	03	[9] Key  _ _ _	17
[4] Key  _ _ _	14	[0] Key  _ _ _	00
[5] Key  _ _ _	15	* Key  _ _ _	17
[6] Key  _ _ _	06	# Key  _ _ _	11

**[21] Audio Control Telephone Mode Key Programming**

	<i>Default</i>		<i>Default</i>
Mode Key & [1]    _ _	00	Mode Key & [7]    _ _	00
Mode Key & [2]    _ _	00	Mode Key & [8]    _ _	00
Mode Key & [3]    _ _	00	Mode Key & [9]    _ _	09
Mode Key & [4]    _ _	00	Mode Key & [0]    _ _	00
Mode Key & [5]    _ _	00	Mode Key & [*]    _ _	00
Mode Key & [6]    _ _	00	Mode Key & [#]    _ _	00

**[30] First Audio Control Options (✓ Denotes Option Default)**

Opt	Option ON	Option OFF
1	<input type="checkbox"/> Zone 1 Alarm Enabled	✓ <input type="checkbox"/> Disabled
2	<input type="checkbox"/> Zone 2 Alarm Enabled	✓ <input type="checkbox"/> Disabled
3	<input type="checkbox"/> Zone 3 Alarm Enabled	✓ <input type="checkbox"/> Disabled
4	<input type="checkbox"/> Zone 4 Alarm Enabled	✓ <input type="checkbox"/> Disabled
5	<input type="checkbox"/> Zone 5 Alarm Enabled	✓ <input type="checkbox"/> Disabled
6	<input type="checkbox"/> Zone 6 Alarm Enabled	✓ <input type="checkbox"/> Disabled
7	<input type="checkbox"/> Zone 7 Alarm Enabled	✓ <input type="checkbox"/> Disabled
8	<input type="checkbox"/> Zone 8 Alarm Enabled	✓ <input type="checkbox"/> Disabled

**[31] Second Audio Control Options (✓ Denotes Option Default)**

Opt	Option ON	Option OFF
1	<input type="checkbox"/> Zone 9 Alarm Enabled	✓ <input type="checkbox"/> Disabled
2	<input type="checkbox"/> Zone 10 Alarm Enabled	✓ <input type="checkbox"/> Disabled
3	<input type="checkbox"/> Zone 11 Alarm Enabled	✓ <input type="checkbox"/> Disabled
4	<input type="checkbox"/> Zone 12 Alarm Enabled	✓ <input type="checkbox"/> Disabled
5	<input type="checkbox"/> Zone 13 Alarm Enabled	✓ <input type="checkbox"/> Disabled
6	<input type="checkbox"/> Zone 14 Alarm Enabled	✓ <input type="checkbox"/> Disabled
7	<input type="checkbox"/> Zone 15 Alarm Enabled	✓ <input type="checkbox"/> Disabled
8	<input type="checkbox"/> Zone 16 Alarm Enabled	✓ <input type="checkbox"/> Disabled

**[32] Third Audio Control Options (✓ Denotes Option Default)**

Opt	Option ON	Option OFF
1	<input type="checkbox"/> Zone 17 Alarm Enabled	<input checked="" type="checkbox"/> Disabled
2	<input type="checkbox"/> Zone 18 Alarm Enabled	<input checked="" type="checkbox"/> Disabled
3	<input type="checkbox"/> Zone 19 Alarm Enabled	<input checked="" type="checkbox"/> Disabled
4	<input type="checkbox"/> Zone 20 Alarm Enabled	<input checked="" type="checkbox"/> Disabled
5	<input type="checkbox"/> Zone 21 Alarm Enabled	<input checked="" type="checkbox"/> Disabled
6	<input type="checkbox"/> Zone 22 Alarm Enabled	<input checked="" type="checkbox"/> Disabled
7	<input type="checkbox"/> Zone 23 Alarm Enabled	<input checked="" type="checkbox"/> Disabled
8	<input type="checkbox"/> Zone 24 Alarm Enabled	<input checked="" type="checkbox"/> Disabled

**[33] Fourth Audio Control Options (✓ Denotes Option Default)**

Opt	Option ON	Option OFF
1	<input type="checkbox"/> Zone 25 Alarm Enabled	<input checked="" type="checkbox"/> Disabled
2	<input type="checkbox"/> Zone 26 Alarm Enabled	<input checked="" type="checkbox"/> Disabled
3	<input type="checkbox"/> Zone 27 Alarm Enabled	<input checked="" type="checkbox"/> Disabled
4	<input type="checkbox"/> Zone 28 Alarm Enabled	<input checked="" type="checkbox"/> Disabled
5	<input type="checkbox"/> Zone 29 Alarm Enabled	<input checked="" type="checkbox"/> Disabled
6	<input type="checkbox"/> Zone 30 Alarm Enabled	<input checked="" type="checkbox"/> Disabled
7	<input type="checkbox"/> Zone 31 Alarm Enabled	<input checked="" type="checkbox"/> Disabled
8	<input type="checkbox"/> Zone 32 Alarm Enabled	<input checked="" type="checkbox"/> Disabled

**[34] Fifth Audio Control Options (✓ Denotes Option Default)**

Opt	Option ON	Option OFF
1	<input type="checkbox"/> Zone 33 Alarm Enabled	<input checked="" type="checkbox"/> Disabled
2	<input type="checkbox"/> Zone 34 Alarm Enabled	<input checked="" type="checkbox"/> Disabled
3	<input type="checkbox"/> Zone 35 Alarm Enabled	<input checked="" type="checkbox"/> Disabled
4	<input type="checkbox"/> Zone 36 Alarm Enabled	<input checked="" type="checkbox"/> Disabled
5	<input type="checkbox"/> Zone 37 Alarm Enabled	<input checked="" type="checkbox"/> Disabled
6	<input type="checkbox"/> Zone 38 Alarm Enabled	<input checked="" type="checkbox"/> Disabled
7	<input type="checkbox"/> Zone 39 Alarm Enabled	<input checked="" type="checkbox"/> Disabled
8	<input type="checkbox"/> Zone 40 Alarm Enabled	<input checked="" type="checkbox"/> Disabled

**[35] Sixth Audio Control Options (✓ Denotes Option Default)**

Opt	Option ON	Option OFF
1	<input type="checkbox"/> Zone 41 Alarm Enabled	✓ <input type="checkbox"/> Disabled
2	<input type="checkbox"/> Zone 42 Alarm Enabled	✓ <input type="checkbox"/> Disabled
3	<input type="checkbox"/> Zone 43 Alarm Enabled	✓ <input type="checkbox"/> Disabled
4	<input type="checkbox"/> Zone 44 Alarm Enabled	✓ <input type="checkbox"/> Disabled
5	<input type="checkbox"/> Zone 45 Alarm Enabled	✓ <input type="checkbox"/> Disabled
6	<input type="checkbox"/> Zone 46 Alarm Enabled	✓ <input type="checkbox"/> Disabled
7	<input type="checkbox"/> Zone 47 Alarm Enabled	✓ <input type="checkbox"/> Disabled
8	<input type="checkbox"/> Zone 48 Alarm Enabled	✓ <input type="checkbox"/> Disabled

**[36] Seventh Audio Control Options (✓ Denotes Option Default)**

Opt	Option ON	Option OFF
1	<input type="checkbox"/> Zone 49 Alarm Enabled	✓ <input type="checkbox"/> Disabled
2	<input type="checkbox"/> Zone 50 Alarm Enabled	✓ <input type="checkbox"/> Disabled
3	<input type="checkbox"/> Zone 51 Alarm Enabled	✓ <input type="checkbox"/> Disabled
4	<input type="checkbox"/> Zone 52 Alarm Enabled	✓ <input type="checkbox"/> Disabled
5	<input type="checkbox"/> Zone 53 Alarm Enabled	✓ <input type="checkbox"/> Disabled
6	<input type="checkbox"/> Zone 54 Alarm Enabled	✓ <input type="checkbox"/> Disabled
7	<input type="checkbox"/> Zone 55 Alarm Enabled	✓ <input type="checkbox"/> Disabled
8	<input type="checkbox"/> Zone 56 Alarm Enabled	✓ <input type="checkbox"/> Disabled

**[37] Eighth Audio Control Options (✓ Denotes Option Default)**

Opt	Option ON	Option OFF
1	<input type="checkbox"/> Zone 57 Alarm Enabled	✓ <input type="checkbox"/> Disabled
2	<input type="checkbox"/> Zone 58 Alarm Enabled	✓ <input type="checkbox"/> Disabled
3	<input type="checkbox"/> Zone 59 Alarm Enabled	✓ <input type="checkbox"/> Disabled
4	<input type="checkbox"/> Zone 60 Alarm Enabled	✓ <input type="checkbox"/> Disabled
5	<input type="checkbox"/> Zone 61 Alarm Enabled	✓ <input type="checkbox"/> Disabled
6	<input type="checkbox"/> Zone 62 Alarm Enabled	✓ <input type="checkbox"/> Disabled
7	<input type="checkbox"/> Zone 63 Alarm Enabled	✓ <input type="checkbox"/> Disabled
8	<input type="checkbox"/> Zone 64 Alarm Enabled	✓ <input type="checkbox"/> Disabled

**[38] Ninth Audio Control Options** (✓ Denotes Option Default)

Opt	Option ON	Option OFF
1	<input type="checkbox"/> Tamper Enabled	✓ <input type="checkbox"/> Disabled
2	<input type="checkbox"/> Openings & Closings Enabled	✓ <input type="checkbox"/> Disabled
3	<input type="checkbox"/> A Key Alarm Enabled	✓ <input type="checkbox"/> Disabled
4	<input type="checkbox"/> P Key Alarm Enabled	✓ <input type="checkbox"/> Disabled
5	<input type="checkbox"/> Duress Alarm Enabled	✓ <input type="checkbox"/> Disabled
6	<input type="checkbox"/> Zone Expander Superv Alarm	✓ <input type="checkbox"/> Disabled
7	<input type="checkbox"/> Opening After Alarm Enabled	✓ <input type="checkbox"/> Disabled
8	<input type="checkbox"/> Future Use	

**[40] Microphone Input Assignments, Zones 1-8**

(Enter nearest microphone input number (01-04, 00=Not Used) **Default**)

Zone 1 Microphone Input Assignment	_ _	00
Zone 2 Microphone Input Assignment	_ _	00
Zone 3 Microphone Input Assignment	_ _	00
Zone 4 Microphone Input Assignment	_ _	00
Zone 5 Microphone Input Assignment	_ _	00
Zone 6 Microphone Input Assignment	_ _	00
Zone 7 Microphone Input Assignment	_ _	00
Zone 8 Microphone Input Assignment	_ _	00

**[41] Microphone Input Assignments, Zones 9-16**

(Enter nearest microphone input number (01-04, 00=Not Used) **Default**)

Zone 9 Microphone Input Assignment	_ _	00
Zone 10 Microphone Input Assignment	_ _	00
Zone 11 Microphone Input Assignment	_ _	00
Zone 12 Microphone Input Assignment	_ _	00
Zone 13 Microphone Input Assignment	_ _	00
Zone 14 Microphone Input Assignment	_ _	00
Zone 15 Microphone Input Assignment	_ _	00
Zone 16 Microphone Input Assignment	_ _	00



**[42] Microphone Input Assignments, Zones 17-24**

(Enter nearest microphone input number (01-04, 00=Not Used) *Default*)

Zone 17 Microphone Input Assignment	_ _	00
Zone 18 Microphone Input Assignment	_ _	00
Zone 19 Microphone Input Assignment	_ _	00
Zone 20 Microphone Input Assignment	_ _	00
Zone 21 Microphone Input Assignment	_ _	00
Zone 22 Microphone Input Assignment	_ _	00
Zone 23 Microphone Input Assignment	_ _	00
Zone 24 Microphone Input Assignment	_ _	00

**[43] Microphone Input Assignments, Zones 25-32**

(Enter nearest microphone input number (01-04, 00=Not Used) *Default*)

Zone 25 Microphone Input Assignment	_ _	00
Zone 26 Microphone Input Assignment	_ _	00
Zone 27 Microphone Input Assignment	_ _	00
Zone 28 Microphone Input Assignment	_ _	00
Zone 29 Microphone Input Assignment	_ _	00
Zone 30 Microphone Input Assignment	_ _	00
Zone 31 Microphone Input Assignment	_ _	00
Zone 32 Microphone Input Assignment	_ _	00

**[44] Microphone Input Assignments, Zones 33-40**

(Enter nearest microphone input number (01-04, 00=Not Used) *Default*)

Zone 33 Microphone Input Assignment	_ _	00
Zone 34 Microphone Input Assignment	_ _	00
Zone 35 Microphone Input Assignment	_ _	00
Zone 36 Microphone Input Assignment	_ _	00
Zone 37 Microphone Input Assignment	_ _	00
Zone 38 Microphone Input Assignment	_ _	00
Zone 39 Microphone Input Assignment	_ _	00
Zone 40 Microphone Input Assignment	_ _	00

**[45] Microphone Input Assignments, Zones 41-48**

(Enter nearest microphone input number (01-04, 00=Not Used) **Default**

Zone 41 Microphone Input Assignment	_ _	00
Zone 42 Microphone Input Assignment	_ _	00
Zone 43 Microphone Input Assignment	_ _	00
Zone 44 Microphone Input Assignment	_ _	00
Zone 45 Microphone Input Assignment	_ _	00
Zone 46 Microphone Input Assignment	_ _	00
Zone 47 Microphone Input Assignment	_ _	00
Zone 48 Microphone Input Assignment	_ _	00

**[46] Microphone Input Assignments, Zones 49-56**

(Enter nearest microphone input number (01-04, 00=Not Used) **Default**

Zone 49 Microphone Input Assignment	_ _	00
Zone 50 Microphone Input Assignment	_ _	00
Zone 51 Microphone Input Assignment	_ _	00
Zone 52 Microphone Input Assignment	_ _	00
Zone 53 Microphone Input Assignment	_ _	00
Zone 54 Microphone Input Assignment	_ _	00
Zone 55 Microphone Input Assignment	_ _	00
Zone 56 Microphone Input Assignment	_ _	00

**[47] Microphone Input Assignments, Zones 57-64**

(Enter nearest microphone input number (01-04, 00=Not Used) **Default**

Zone 57 Microphone Input Assignment	_ _	00
Zone 58 Microphone Input Assignment	_ _	00
Zone 59 Microphone Input Assignment	_ _	00
Zone 60 Microphone Input Assignment	_ _	00
Zone 61 Microphone Input Assignment	_ _	00
Zone 62 Microphone Input Assignment	_ _	00
Zone 63 Microphone Input Assignment	_ _	00
Zone 64 Microphone Input Assignment	_ _	00



## Limited Warranty

DSC warrants that for a period of one year from the date of purchase, the product shall be free of defects in material and workmanship under normal use and that in fulfillment of such warranty, DSC shall, at its option, repair or replace the defective equipment upon return of the equipment to its repair depot. This warranty applies only to defects in materials and workmanship and not to damage incurred in shipping or handling, or damage due to causes beyond the control of DSC, such as lightning strikes, overvoltage, mechanical shock, water damage or damage arising out of abuse, alteration or improper application of the product.

The foregoing warranty shall apply only to the original buyer and shall be in lieu of any and all other warranties, whether expressed or implied, and of all other obligations or liabilities on the part of DSC. This warranty contains the entire warranty. DSC neither assumes responsibility for, nor authorizes any other person purporting to act on its behalf, to modify or to change this warranty, nor to issue for it any other warranty or liability concerning this product.

In no event shall DSC be liable for any direct, indirect or consequential damages, loss of anticipated profits, loss of time or any other losses incurred by the buyer in connection with the purchase, installation or operation or failure of this product.

### IMPORTANT!

DSC recommends that the entire system be completely tested on a regular basis. However, despite frequent testing, and due to but not limited to criminal tampering or electrical disruption, it is possible for this product to fail to perform as expected.

DSC erklærer herved at denne komponenten overholder alle vigtige krav samt andre bestemmelser givet i direktiv 1999/5/EC.

Por este meio, a DSC, declara que este equipamento está em conformidade com os requisitos essenciais e outras determinações relevantes da Directiva 1999/5/EC.

"DSC bekräftar härmed att denna apparat uppfyller de väsentliga kraven och andra relevanta bestämmelser i Direktivet 1999/5/EC".

Con la presente la Digital Security Controls Ltd dichiara che questo prodotto è conforme ai requisiti essenziali ed altre disposizioni rilevanti relative alla Direttiva 1999/05/CE.

"Por la presente, DSC, declara que este equipo cumple con los requisitos requeridos por la Directiva 1999/5/EC".

Hierdurch erklärt DSC, daß dieses Gerät den erforderlichen Bedingungen und Voraussetzungen der Richtlinie 1999/5/EC entspricht.

"Δια του παρόντος, η DSC, δηλώνει ότι αυτή η συσκευή είναι σύμφωνη με τις ουσιαστικές απαιτήσεις και με όλες τις άλλες σχετικές αναφορές της Οδηγίας 1999/5/EC".

Hierbij verklaart DSC dat dit toestel in overeenstemming is met de eisen en bepalingen van richtlijn 1999/5/EC.

Par la présente, DSC déclare que cet article est conforme aux exigences essentielles et autres pertinentes stipulations de la directive 1999/5/EC.

DSC vakuuttaa laitteen täyttävän direktiivin 1999/5/EC olennaiset vaatimukset.

Hereby, DSC, declares that this device is in compliance with the essential requirements and other relevant provisions of Directive 1999/5/EC.

The complete R & TTE Declaration of Conformity can be found at [www.dsc.com/intl/rttedirect.htm](http://www.dsc.com/intl/rttedirect.htm).



29034680R003

©2004 Digital Security Controls Ltd.

Toronto, Canada • [www.dsc.com](http://www.dsc.com)

Technical Support: 1-800-387-3630 (Canada & U.S.) or 905-760-3036

Printed in Canada