

# DSC® FSB-210 Series Smoke Detector

## Installation and Operating Instructions

Read this instruction sheet thoroughly before installation and use of the FSB-210 Series Smoke Detector  
This Installation Sheet must be used in conjunction with the appropriate Alarm Controller Installation Manual.

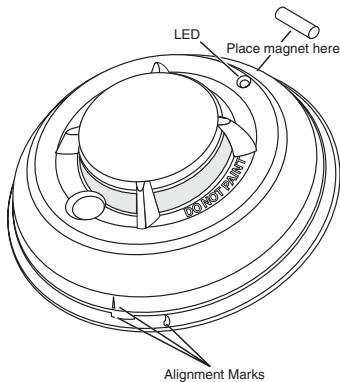

### Control Panel Compatibility

FSB-210 smoke detectors are addressable system detectors that are only for use with DSC fire and security control panels equipped with the compatible interface. The FSB-210 smoke detectors cannot be used with a standard 2-wire smoke detector interface. Any standard 2-wire smoke detector, including the DSC FSA Series, will not operate on an addressable circuit. The FSB-210 series and the FSA Series are not compatible, interchangeable or substitutable.

The addressable interfaces have a proprietary power and signaling system. Voltage ratings are not indicative of compatibility. The current rating is provided for circuit loading calculations only. Please refer to the control panel information for details on the installation of addressable circuits.

FSB-210 detectors are compatible with the following control units:

- PC5010/PC5015/PC5020/PC5020CF v2.x with PC5100 interface module. Maximum 32 detectors can be installed.
- PC4010/PC4010CF/PC4020/PC4020CF v3.x. Maximum 112 detectors can be installed.

### Operation

Approximately every 7 to 8 seconds the unit tests for a smoke or heat alarm condition. During this sequence the unit also performs self diagnostics, and checks for faults. During normal operation the LED will flash every 50 seconds.

### Smoke Alarm

The smoke detector has a nominal fixed alarm sensitivity (refer to the *Specifications* section on the back page) and it will go into alarm when the signal level exceeds the

'alarm' threshold and send the alarm signal to the control panel. During an alarm the LED will flash every second.

### Smoke - Drift Compensation

The detector automatically compensates for long-term environmentally induced changes to maintain a constant smoke sensitivity. When the drift compensation has reached its high or low limit of adjustment, the detector will go into the trouble state.

### Heat Alarm

The heat detector will go into alarm when the heat signal level exceeds the heat alarm threshold (135°F/57°C); and send the alarm signal to the control panel. During an alarm the LED will flash every second.

### Alarm Indications

Condition	LED
Normal/Sensitivity in Production Range	Flash 1/50s
Alarm Smoke/Heat	Flash 1/1s
Low Power Trouble	OFF
Other Fault/Trouble	OFF
Smoke Test - Failed	OFF

## Installer Instructions

### 1. Smoke Detector Placement

On smooth ceilings, detectors may be spaced 9.1m (30ft) apart as a guide. Other spacing may be required depending on ceiling height, air movement, the presence of joists, uninsulated ceilings, etc. Consult National Fire Alarm Code NFPA 72, Chapter 11 or other appropriate national standards for installation recommendations.

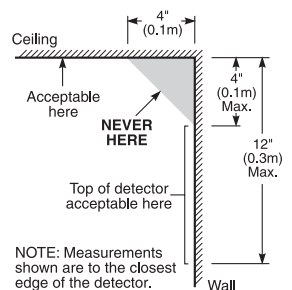

- Do **NOT** locate smoke detectors at the top of peaked or gabled ceilings; the dead air space in these locations may prevent the unit from detecting smoke. Avoid areas with turbulent air flow, (near doors, fans or windows). Rapid air movement around the detector may prevent smoke from entering the unit.
- Do **NOT** locate detectors in areas of high humidity.
- Do **NOT** locate detectors in areas where the temperature rises above 38°C (100°F) or falls below 5°C (41°F).

**Install Smoke detectors in accordance with NFPA 72, Chapter 11:** "Smoke detectors shall be installed outside of each sleeping area in the immediate vicinity of the bedrooms and on each additional story of the family living unit, including basements and excluding crawl spaces and unfinished attics. In new construction, a smoke detector also shall be installed in each sleeping room."

## 2. Mount Smoke Detector Backplate

Mount backplate on standard 4" octagonal electrical box using the screws provided.

**NOTE:** Power supply must be supplied from a UL Listed alarm control unit. Install wiring in accordance with the appropriate national and local electrical codes.

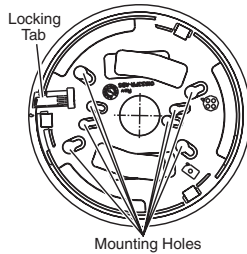

## 3. Wiring

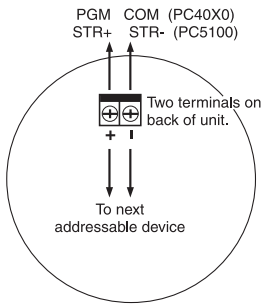

Refer to the connection diagram in this section. Before connecting the unit, prepare the wires from the electrical box for connection; the wires should not be frayed or bent.

**CAUTION: If power connections are reversed, the unit will not operate. The unit is protected against damage from incorrect wiring.**

When wiring is completed, inspect the wiring and correct any errors before applying

power to the unit. When the wiring has been thoroughly reviewed, neatly insert the wires into the electrical box and secure the unit to the mounting plate.

**NOTE:** This equipment should be installed in accordance with the National Fire Protection Association Standard 72 (National Fire Protection Association, Batterymarch Park, Quincy, MA 02269).

## Dust Cover

The dust cover is intended to protect the smoke detector from dust and dirt entry while the unit is not in service.

**CAUTION: The dust cover protects the unit ONLY when it is not in service. Remove the dust cover before use.**

## Device Enrollment

The serial number located on the back of the device must be enrolled into the alarm control panel via Installer's Programming ([\*][8] [Installer Code]). This procedure is outlined for Power panels in the PC5100 Installation Manual and for the PC4010/4020 v3.x in the control panel Installation Manual.

**WARNING: Connect only DSC addressable series devices to the addressable loop connections. Connection of any other type of device will impair operation. Devices other than addressable series devices which require power to operate must be powered separately.**

**Do NOT use looped wire under terminals for system supervision. Break the wire run to provide supervision of connections.**

## 4. Mounting

### Detector Installation

Position the detector on to the base plate using the detector and base plate alignment marks. Press the detector gently in place while rotating the detector clockwise until the detector snaps into place. Remove the side tab from the locking tab to lock in place (optional).

**Removal:** If the side tab is removed to lock the detector, depress tab with a small flat blade screwdriver and rotate the detector counter-clockwise until the alignment marks line up. Remove detector.

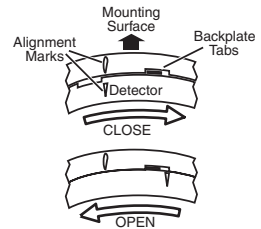

## 5. Test Unit

1. Program the Panel for Smoke Test. Refer to the Alarm Control Panel Installation Manual for details.

**NOTE: If the detector is in one of the following states when test is initiated, it will not enter an alarm state:**

- Compensation trouble.
  - Failure of heat or smoke detector.
  - Other internal faults that could prevent a smoke or heat alarm.
2. Use the FSD-100 meter to read the trouble status after testing. Refer to the FSD-100 User Guide for details.

**NOTE: Place the meter close to the LED until it begins to flash every 2 seconds. Then hold the meter on the opposite side of the LED and read the message. The detector will send out a test message 7 times in a 2-second interval until the LED stops flashing.**

## 6. Compensation Reset

Cleaning, replacement of the smoke sensor, or other changes may change the background signal/noise of the detector; this requires the drift compensation be reset. Compensation trouble is one of the faults indicated when the LED indicator is OFF.

- Remove power from the unit, then press and hold the test button for 30 seconds to power down unit.
- Power up unit while pressing the test button. The LED will flash; when 5 seconds has elapsed. Release the test button within 1 second after the fifth LED flash.
- The LED will flash every 8 seconds for 1 minute. When the detector stops flashing test the detector to verify normal operation.

# Owner's Instructions

---

## Fire Safety

It is recommended that a fire safety audit be conducted and an escape plan be developed.

### Fire Safety Audit

1. Are all electrical appliances/equipment and outlets in safe condition? Check for frayed cords, overloaded lighting circuits, etc. If you are uncertain about the condition of any electrical equipment or service, have a professional evaluation performed.
2. Are all flammable liquids safely stored in closed containers, and in cool, well ventilated areas? Avoid cleaning the unit with flammable liquids.
3. Are hazardous materials stored in safe locations?
4. Are furnaces and wood burning appliances properly installed, clean, and in good working order? If in doubt, have a professional evaluation.

### Escape Planning

There is often very little time between the detection of a fire and the time it becomes deadly. Because of this, it is very important that an escape plan be developed and rehearsed.

- Include all family members/employees when developing an escape plan.
- Study the possible escape routes from each location within the home/building. Since many fires occur at night, give special attention to the escape routes from sleeping quarters (if applicable).
- It is essential that escape from a bedroom be possible without opening the interior door.

### *Consider the following when making your escape plans:*

- Ensure that doors and windows that open to the outside are easily opened. Ensure that they are not painted shut and that the locking mechanisms operate smoothly.
- Develop rescue plans for children, the elderly and/or handicapped persons if opening the exits or using the exit is too difficult for them. This plan includes making sure that those who are to perform the rescue can promptly hear the fire warning signal.
- If the exit is above the ground level, provide an approved fire ladder or rope, as well as training in its use.
- Keep all exits clear. Be sure to remove snow from all paths in the winter and remove objects that are blocking any of the exits.
- Have a predetermined assembly point where everyone can be accounted for; for example, across the street or in a parking lot.
- Once everyone is out of the home/building, call the Fire Department.

- A good plan emphasizes a quick escape. Do not investigate first or attempt to fight the fire, and do not attempt to rescue belongings or valuables as this takes up time. Once outside, do not re-enter the premises; wait for the Fire Department.
- Write the plan down and rehearse it frequently so if an emergency occurs, everyone will know what to do. Revise the plan as conditions change; for example, when there are more/fewer employees or if there are changes to the home/building.
- Make sure your fire warning system is operational by conducting weekly tests. If you are unsure about system operation, contact your smoke detector installer or dealer.
- DSC recommends that you contact your local Fire Department and request further information on fire safety and escape planning. If available, have your local fire prevention officer conduct a fire safety inspection.

### Testing

DSC recommends regular testing of Smoke Detectors to ensure correct operation. Contact your Installer or Dealer for servicing and testing.

### Maintenance

The smoke detector is designed to require minimum maintenance. If the case becomes dusty, vacuum with a small brush attachment. If the case is greasy, wipe the case gently with a soft cloth slightly dampened with soapy water.

**Never disassemble the smoke detector; there are no user serviceable parts inside the unit. Never paint the unit. Paint may prevent smoke from entering the unit. If you are planning renovations or repainting, contact your installer and ask that the unit be temporarily removed until work is complete.**

If the unit is located in an area where it is exposed to high levels of dust or insects and causes false alarms, it may require service; contact your smoke detector installer or dealer.

## Smoke Detector Family

Model	Heat	Max. Alarm Current Draw
FSB-210B	NO	1.8mA
FSB-210BT	YES	1.8mA

## Specifications

Diameter (base) . . . . . 5.8in (147mm)  
Height (including base) . . . . . 2.077in (528mm)  
Operating Temperature . . . . . 32°-100°F (0°-37.8°C)  
Humidity . . . . . 5%-93% RH, non-condensing  
Operating Voltage Range . . . . . 8 -12VDC  
Maximum Standby Current . . . . . 1.6mA@12  
Smoke Sensitivity UL . . . . . 3% ± 0.8%/ft obscuration  
Heat Alarm . . . . . 135°F (57°C)

## FCC Compliance Statement

**CAUTION: Changes or modifications not expressly approved by DSC could void your authority to use this equipment.**

This equipment has been tested and found to comply with the limits for a Class B digital device, pursuant to Part 15 of the FCC Rules. These limits are designed to provide reasonable protection against harmful interference in a residential installation. This equipment generates, uses and can radiate radio frequency energy and, if not installed and used in accordance with the instructions, may cause harmful interference to radio communications. However, there is no guarantee that interference will not occur in a particular installation. If this equipment does cause harmful interference to radio or television reception, which can be determined by turning the equipment off and on, the user is encouraged to try to correct the interference by one or more of the following measures:

- Re-orient the receiving antenna.
- Increase the separation between the equipment and receiver.
- Connect the equipment into an outlet on a circuit different from that to which the receiver is connected.
- Consult the dealer or an experienced radio/television technician for help.

The user may find the following booklet prepared by the FCC useful: "How to Identify and Resolve Radio/Television Interference Problems". This booklet is available from the U.S. Government Printing Office, Washington D.C. 20402, Stock # 004-000-00345-4.

